

L-GAGE™ Q50A Series with Analog Output

LED-Based Linear Displacement Sensor with Analog Output and TEACH-Mode Programming



NOTE: Q50B models also available, with 100 to 400 mm range

L-GAGE Q50A Analog Output Sensor Features

- Fast, easy-to-use TEACH-Mode programming; no potentiometer adjustments
- Selectable output response speeds: 4 milliseconds or 64 milliseconds (see hookup)
- Teach a sensing window size and position, or a 50 mm window centered on a taught point
- Two sensing ranges, depending on model: 50 to 150 mm (visible red beam models), and 50 to 200 mm (infrared beam models)
- Sensor linearity is better than 1.5 mm
- Banner's patented scalable analog output (U.S. patent #6,122,039) automatically distributes the output signal over the width of the programmed sensing window
- Analog output slope can be either positive or negative, depending upon which window limit is programmed first
- Two bicolor Status LEDs
- Choose 2 meter or 9 meter unterminated cable, or swivel 5-pin Euro-style QD connector
- Rugged construction withstands demanding sensing environments; rated IEC IP67, NEMA 6
- Select models with either visible red or infrared beam
- Select models with either a 0-10V or 4-20 mA output



WARNING . . .

Not To Be Used for Personnel Protection

Never use these products as sensing devices for personnel protection. Doing so could lead to serious injury or death.

These sensors do NOT include the self-checking redundant circuitry necessary to allow their use in personnel safety applications. A sensor failure or malfunction can cause either an energized or de-energized sensor output condition. Consult your current Banner Safety Products catalog for safety products which meet OSHA, ANSI and IEC standards for personnel protection.

L-GAGE Q50A Analog Output Sensor Models

Model Number	Sensing Range	Cable*	Supply Voltage	Beam	Output	
Q50AVI	50 to 150 mm (2.0" to 5.9")	5-wire, 2 m (6.5') cable	15 to 30V dc	Visible Red LED	4 to 20 mA	
Q50AVIQ		5-pin Euro-style QD				
Q50AVU		5-wire, 2 m (6.5') cable			0 to 10V	
Q50AVUQ		5-pin Euro-style QD				
Q50AI	50 to 200 mm (2.0" to 7.9")	5-wire, 2 m (6.5') cable		15 to 30V dc	Infrared LED	4 to 20 mA
Q50AIQ		5-pin Euro-style QD				
Q50AU		5-wire, 2 m (6.5') cable				0 to 10V
Q50AUQ		5-pin Euro-style QD				

* 9 meter cables are available by adding suffix "W/30" to the model number of any cabled sensor (e.g., Q50AVI W/30). A model with a QD connector requires a mating cable; see page 8.

L-GAGE Q50A – Analog Output Sensor

L-GAGE Q50A Analog Output Sensor Overview

The Q50A is an easy-to-use triangulation sensor which provides a sophisticated, yet cost-effective solution for demanding measurement applications. Q50A Series sensors feature compact, all-in-one design and require no separate controller.

Near and far sensing window limits are set quickly using simple push-button or remote signal TEACH-mode programming. The analog output has the option of being set with a sensing distance centered within a 50 mm window. The sensor features Banner's patented digital signal processing algorithm (U.S. patent #6,122,039), which automatically distributes the 0 to 10V dc (or 4 to 20 mA) output signal over the width of the programmed window.

Optical Triangulation

The function of the Q50A Sensor is based on optical triangulation (see Figure 1). The emitter circuitry and optics create a light source which is directed toward a target. The light source bounces off the target, scattering some of its light through the sensor's receiver lens to its position-sensitive-device (PSD) receiver element. The target's distance from the receiver determines the light's angle to the receiver element; this angle determines where the returned light will touch the PSD receiver element.

The position of the light on the PSD receiver element is processed through analog and digital electronics and analyzed by the microprocessor, which calculates the appropriate output value. The analog output provides either a current or voltage output proportional to the target's position within the user-programmed analog window limits (see page 4).

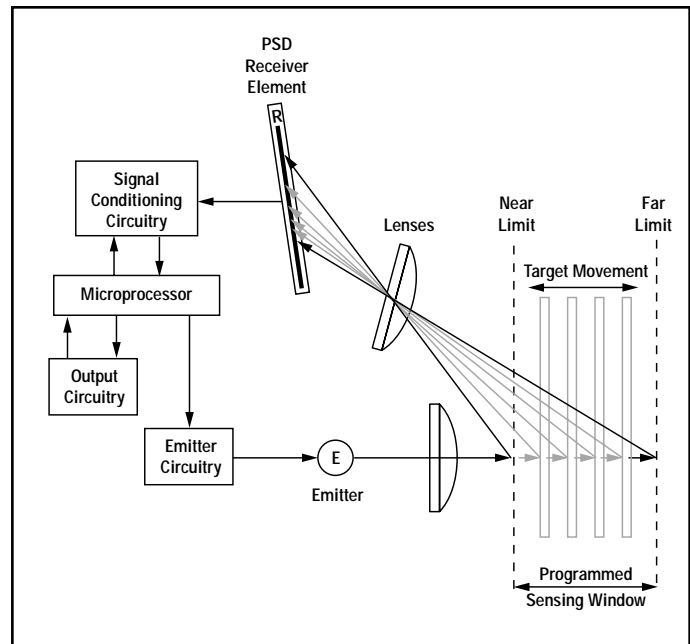

Figure 1. Using optical triangulation to determine sensing distance

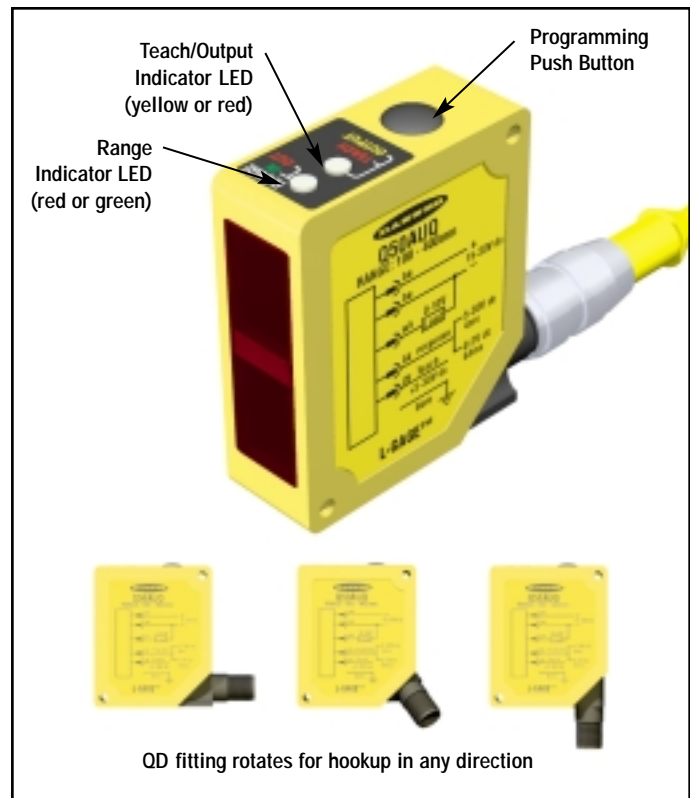

Figure 2. L-GAGE Q50A sensor features

Using the L-GAGE Q50A Analog Output Sensor

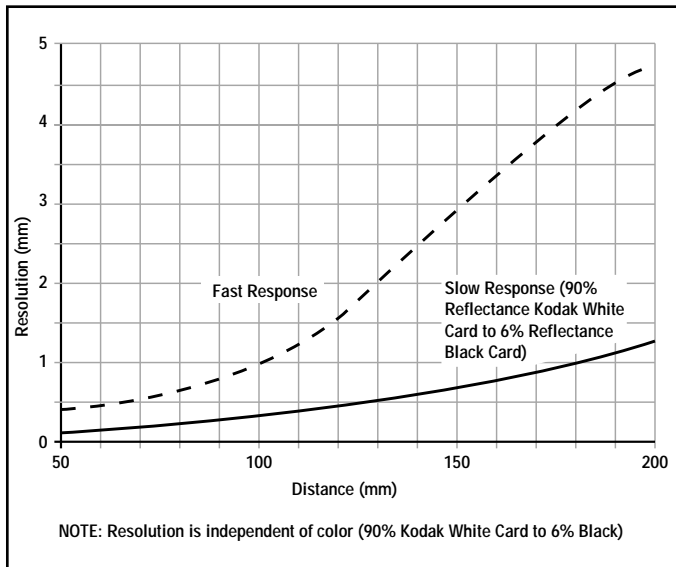

Figure 3. L-GAGE Q50A resolution
Q50A (infrared models) range is 50 - 200 mm
Q50AV (visible models) range is 50 - 150 mm

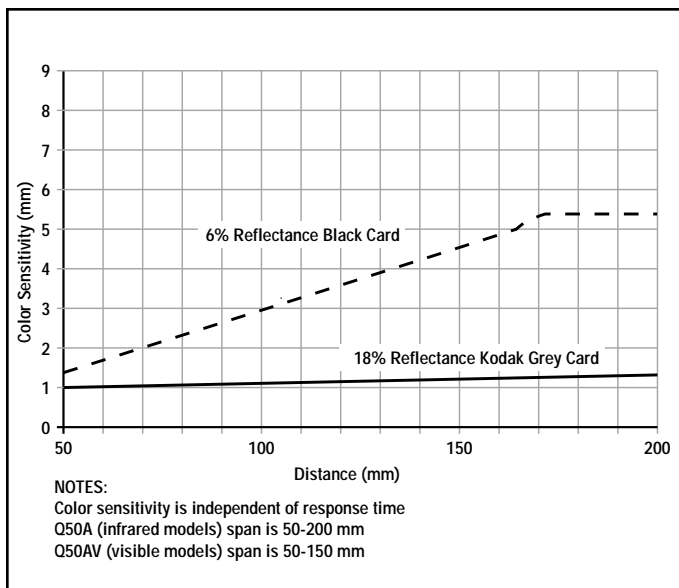

Figure 4. L-GAGE Q50A color sensitivity (This represents the expected change in output when the target color is changed from a 90% reflectance Kodak White Card to a 6% and 18% reflectance surface.)

Response Speed

To control the response speed, connect the black wire as follows:

- Fast Speed (4 ms):** Connect black wire to +5 to 30V dc
- Slow Speed (64 ms):** Connect black wire to 0 to +2V dc (or open connection)

Window Limits

Window limits may be taught to the sensor either remotely (using the gray wire) or by using the sensor's Teach push button.

The Q50A sensor operates in two modes: TEACH (or programming) mode and RUN mode.

NOTE: All LED indicators momentarily go OFF when the sensor changes state between RUN and TEACH modes.

Indicator Status Conditions

Indicator	Status
Range LED (green/red)	Green — Target is within sensing range Red — Target is outside sensing range OFF — Sensor Power OFF
Teach/Output LED (yellow/red)	Yellow — Target is within taught window limits OFF — Target is outside taught window limits Red — Sensor is in TEACH mode

TEACH-Mode Programming

Push-Button Procedure

1. Press the Teach push button until the Teach LED turns red (hold button in for about 2 seconds). This indicates the sensor is waiting for the first window limit.
2. Position the target for the first limit. The Range LED should be green, indicating a valid target. Briefly "click" the Teach push button. This will teach the sensor the first limit. The Teach LED will flash red at 2 Hz to acknowledge receiving the first window limit; it is now waiting for the second limit.
3. Position the target for the second limit and "click" the Teach push button again to teach the sensor the second limit. The Teach LED will return to either yellow or OFF as the sensor returns to RUN mode.

L-GAGE Q50A – Analog Output Sensor

Teaching Analog Limits Using a Fixed 50 mm Window

For some analog applications, a fixed sensing window centered about a taught point is required. The TEACH procedure is simple: teaching the same limit twice causes the sensor to program a window centered on the position taught. This window is 50 mm wide (taught position ± 25 mm).

Remote Programming

A function is provided to program the sensor remotely or to disable/enable the push button; this is accomplished via the gray wire. Disabling the push button prevents anyone on the production floor from adjusting any of the programming settings. Connect the gray wire of the Q50A Gauging Sensor to +5 to 30V dc, with a remote programming switch connected between them. NOTE: The impedance of the remote teach input is 15 k Ω .

To program, pulse the wire as illustrated in Figure 5. NOTE: The duration of each pulse (corresponding to a push button "click") is 0.04 to 0.8 seconds.

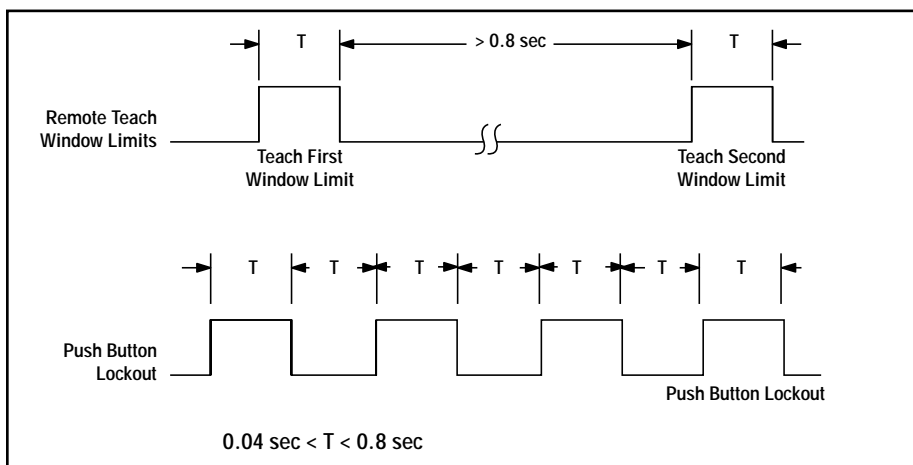

Figure 5. Timing for remote TEACH programming

Run Mode

NOTE: All LED indicators momentarily go OFF when the sensor changes state between RUN and TEACH modes.

Range LED

When the sensor detects a target within its sensing range (either 50 to 150 mm for visible-beam models, or 50 to 200 mm for infrared beam models) the LED will be solid green. In the absence of a target, the Range LED is solid red. Refer to the Indicator Status table on page 3.

Teach/Output LED

In RUN mode, the Output LED is yellow when a target is sensed within the programmed window limits; otherwise the Output LED is red. Refer to the Indicator Status table on page 3.

Analog Output

The Q50A gauging sensor may be programmed for either a positive or a negative output slope (see Figure 6). If the near limit is taught first, the slope will be positive; if the far limit is taught first, the slope will be negative. Banner's patented scalable analog output automatically distributes the output signal over the width of the programmed sensing window. (Output is either 0 to 10V or 4 to 20 mA, depending on model.)

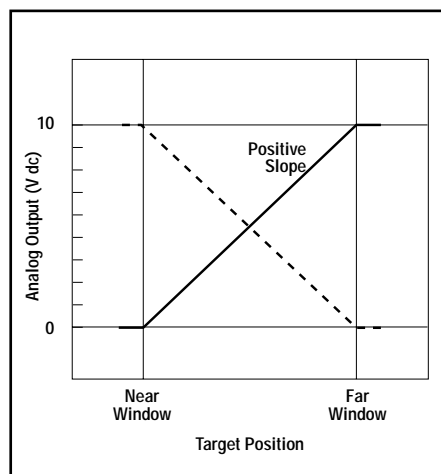

Figure 6. Analog voltage output as a function of target position (loss of signal – 0 Volts)

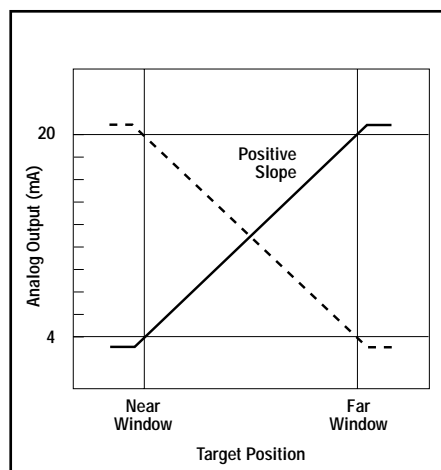

Figure 7. Analog current output as a function of target position (loss of signal – 3.6 mA)

Installation Notes

Some targets (those with a stepped plane facing the sensor, a boundary line, or rounded targets) pose specific problems for sensing distances. For such applications, see Figure 8 for suggested mounting orientations.

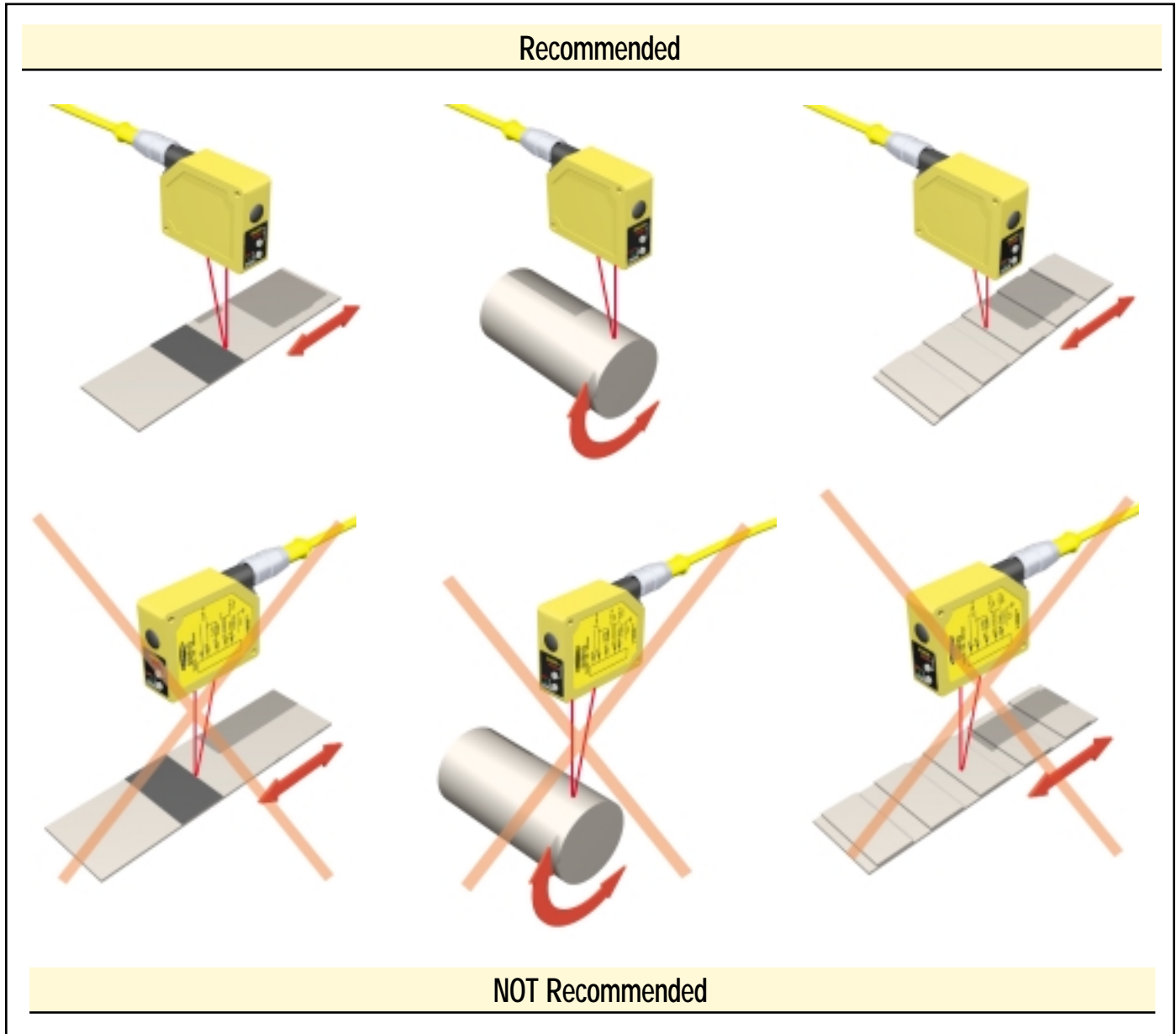

Figure 8. Sensor orientations for typical targets

L-GAGE Q50A – Analog Output Sensor

L-GAGE Q50A Analog Output Sensor Specifications

Sensing Range	Q50AV: 50 to 150 mm (2" to 5.9")		Q50A: 50 to 200 mm (2" to 7.9")					
Supply Voltage	15 to 30V dc (10% maximum ripple); 70 mA max. (exclusive of load)							
Supply Protection Circuitry	Protected against reverse polarity and transient overvoltages							
Delay at Power-up	2 seconds							
Sensing Beam	Wave length	Q50AV: 685 nm (typical)	Q50A: 880 nm (typical)					
	Beam Size	Q50AV: 20 mm dia. (max.)	Q50A: 20 mm dia. (max.)					
Output Configuration	Depending on model 4-20 mA current sourcing models: 1 k Ω max. load @ 24V dc. Max. load = $[(V_{CC} - 4.5)/0.02]\Omega$ Loss of signal or target outside of sensor range: 3.6 mA 0-10V voltage sourcing models: 15 mA max. Loss of signal or target outside of sensor range: 0V							
Output Protection	Protected against short circuit conditions							
Output Response Time	Analog Output	Average Interval	Update Rate	-3 dB Frequency Response				
	Fast:	4 ms	1 ms	112 Hz				
	Slow:	64 ms	4 ms	7 Hz				
Resolution	See Figure 3 for typical values Target Distance: 100 mm Slow Response: 0.5 mm max. Fast Response: 2.0 mm max.							
Linearity	± 1.5 mm							
Color Sensitivity (typical)	See Figure 4							
Temperature Drift	From 0° to 50°C: 0.08 mm/°C From -10° to 55°C: 0.11 mm/°C							
Remote and Speed Input Impedance	15 k Ω							
Remote Teach Input	To Teach: Connect gray wire to +5 to 30V dc To Disable: Connect gray wire to 0 to +2V dc (or open connection)							
Adjustments	Response Speed: Fast Speed: Connect black wire to +5 to 30V dc Slow Speed: Connect black wire to 0 to +2V dc (or open connection)							
Indicators	Range LED Indicator (green/red)	Green — Target is within sensing range Red — Target is outside sensing range OFF — Sensor Power OFF						
	Teach/Output LED Indicator (yellow/red)	Yellow — Target is within taught window limits OFF — Target is outside taught window limits Red — Sensor is in TEACH mode						
Minimum Taught Window		Distance						
	Model #	50 mm	75 mm	100 mm	125 mm	150 mm	175 mm	200 mm
	Q50AV	5 mm	10 mm	15 mm	20 mm	25 mm	–	–
	Q50A	5 mm	10 mm	15 mm	20 mm	25 mm	35 mm	50 mm
Ambient Light Immunity	<10,000 Lux							

L-GAGE Q50A – Analog Output Sensor

L-GAGE Q50A Analog Output Sensor Specifications (continued)

Construction	Housing: Molded ABS/Polycarbonate Window Lens: Acrylic
Environmental Rating	IEC IP67, NEMA 6
Connections	2 m or 9 m 5-conductor PVC-covered attached cable or 5-pin Euro-style quick disconnect
Operating Conditions	Temperature: -10° to +55°C (+14° to +131°F) Max. Rel. Humidity: 90% at +50°C (non-condensing)
Vibration and Mechanical Shock	All models meet Mil. Std. 202F requirements. Method 201A (Vibration: 10 to 60Hz max. double amplitude 0.06", maximum acceleration 10G). Also meets IEC 947-5-2 requirements: 30G, 11 ms duration, half sine wave.
Application Notes	Allow 15-minute warm-up for maximum linearity.
Hardware	M3 hardware is included.

L-GAGE Q50A Dimensions

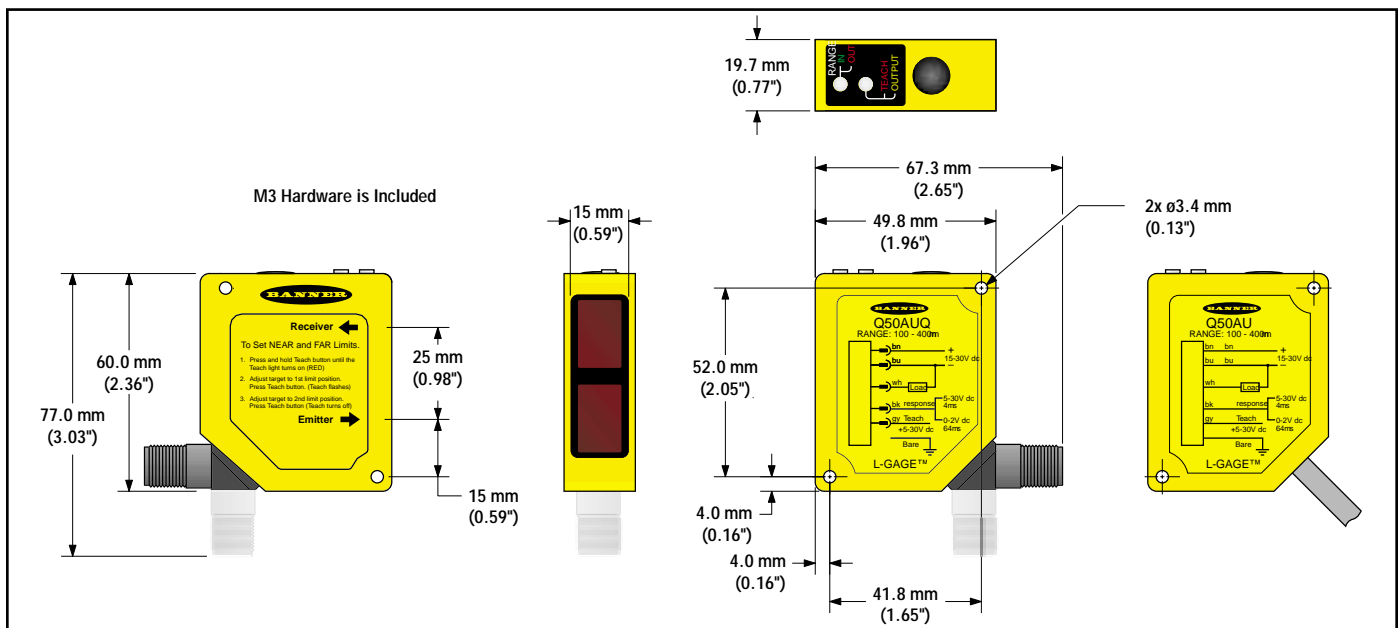

L-GAGE Q50A Hookups

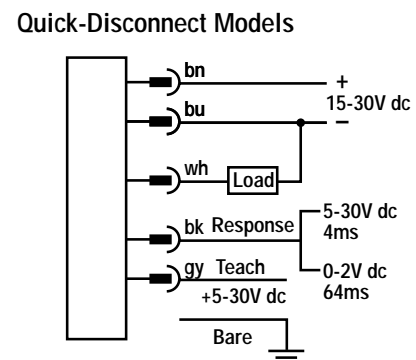
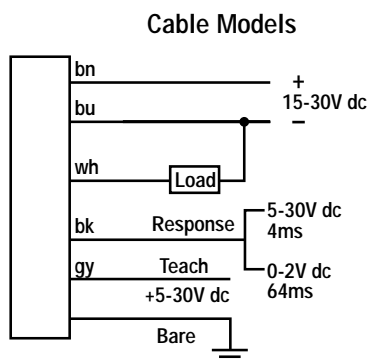



L-GAGE Q50A – Analog Output Sensor

Accessories

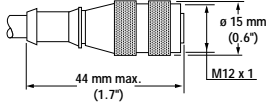
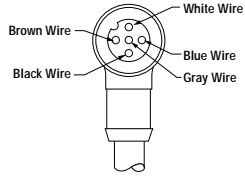
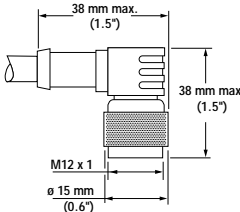
Euro-Style Quick-Disconnect Cables

Style	Model	Length	Connector	Pin-out
5-Pin Euro Straight	MQDEC2-506 MQDEC2-515 MQDEC2-530	2 m (6.5') 5 m (15') 9 m (30')		
5-Pin Euro Right-angle	MQDEC2-506RA MQDEC2-515RA MQDEC2-530RA	2 m (6.5') 5 m (15') 9 m (30')		

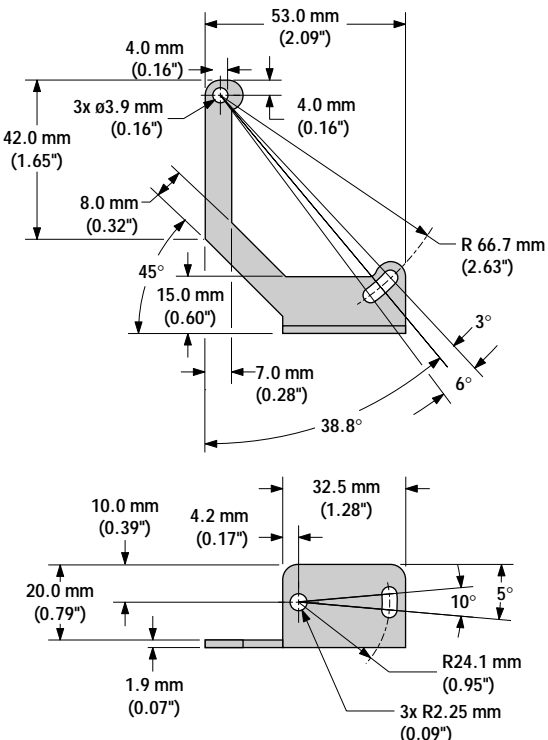
Mounting Brackets

SMBQ50	<ul style="list-style-type: none"> • Right-angle bracket • 14-ga., 304 Stainless Steel
 	

BANNER[®]
more sensors, more solutions

WARRANTY: Banner Engineering Corp. warrants its products to be free from defects for one year. Banner Engineering Corp. will repair or replace, free of charge, any product of its manufacture found to be defective at the time it is returned to the factory during the warranty period. This warranty does not cover damage or liability for the improper application of Banner products. This warranty is in lieu of any other warranty either expressed or implied.