

**BANNER**<sup>®</sup>  
more sensors, more solutions

 **PresencePLUS**<sup>®</sup>  
Vision Sensors & Lighting  
THIRD EDITION

**Request  
PRINT  
Version**

## New models to solve your toughest inspection challenges.

### ▶ PresencePLUS® Pro & P4 COLOR



Offers color sensing in two convenient packages.

**Page 8**

### ▶ Ruggedized Pro Cameras & Lights

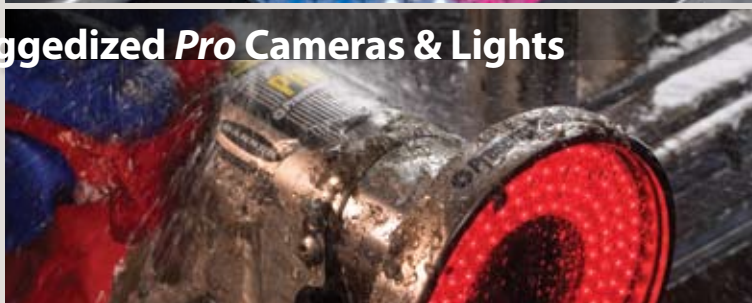

Delivers all the functionality and features of advanced vision into harsh IP68 environments.

**Page 6**

### ▶ P4 OMNI



A compact, integrated vision sensor with features for the most demanding applications.

**Page 16**

### ▶ Bar Code Reading



Decodes 2D and 1D linear bar codes in the toughest low-light/low-contrast conditions.

**Page 10**

### ▶ Lighting



Offers a complete selection of basic and specialty lighting solutions to enhance vision capabilities.

**Page 30**



## When the world thinks of sensors, it thinks of Banner.

With more than 17,000 photoelectric, ultrasonic and vision sensors, and safety products available worldwide, Banner is the most innovative, most experienced name in sensors. For simple to complex applications, Banner has more sensor solutions than any other manufacturer.

The innovation leader with more than 40 years of sensor development and application expertise, Banner understands the challenges of sensing in manufacturing and process industries. Banner has more than 3,000 factory and field representatives worldwide, as well as the largest force of application engineers in the industry who solve thousands of the most challenging applications every year.

## Contents

<i>PresensePLUS</i> Vision Sensing	4
Machine Vision Solutions	6
Color Analysis Solutions	8
ID, Bar Code and Traceability Solutions	10
<i>PresensePLUS</i> Software & Inspection	12
<i>PresensePLUS</i> Features Comparison	14
<i>PresensePLUS Pro</i> and <i>P4 OMNI</i>	16
<i>P4</i> Dedicated-Function Sensors	18
<i>Pro</i> Sensors & Kits	20
<i>P4</i> Sensors & Kits	22
Specifications	24
Hookups & Dimensions	26
System Selection & Integration	28
Lighting Selection Guide	30
Lenses	39
Brackets	40
Monitors & Indicators	43
Cables & Cordsets	44
Interface Modules	46
Power Supplies	46





## Advanced vision solutions from the number one name in sensors.

### Vision sensing from the source you trust.

As the preferred brand of sensors worldwide, Banner knows the challenges of the factory floor. That's why we designed our line of *PresencePLUS*® vision sensors from the ground up, with advanced features, easier setup and operation, rugged design, the most value of any vision systems in the market and, most of all, Banner reliability and support.

### A complete solution.

From a single inspection point to plant-wide vision integration, Banner offers complete vision solutions. Vision sensing has two major elements: hardware—the camera, controller, lighting and brackets; and software—the control system, graphical user interface and image algorithms. Banner provides all of the elements to successfully deploy vision sensing in your facility.

### Visual Inspection Process

1. *Acquire* an image of the part.
2. *Analyze* the image.
3. *Determine* if the inspection passes or fails, and report the results to the manufacturing line. The part then either passes to the next process or is rejected and removed.

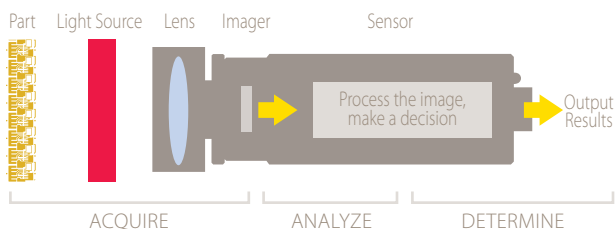

**1. Sensor:** The sensor contains the imager, microprocessor and I/O. The imager has an array of tiny light-sensitive cells (pixels) that convert the target into an image. The microprocessor analyzes the image and makes determinations about it based on user-determined tolerances and criteria. The sensor exports the inspection results through some type of I/O, such as discrete, Ethernet or serial.

**2. Lens:** The lens focuses the light onto the sensor's imager. To determine the lens focal length for an application, specify the field of view and working distance.

**3. Light Source:** The light source is a critical component of any vision inspection system. Lighting is the most powerful tool for creating contrast to amplify the feature of interest, while minimizing other features of the part. Selecting the best light source depends on the shape, surface texture, color and opacity of the part.

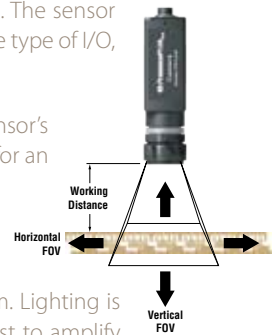

### Opposed Mode



### Proximity Mode



## Affordable sensing technology that's easy to use.

### The best value in vision.

- The best price-performance ratio brings full vision capabilities to all sensor specifiers.
- Simple, easy-to-use interface.
- Easy to justify cost for multiple applications.
- No software maintenance fees—free firmware & PC software upgrades.
- Hundreds of lens and lighting options.
- Superior in-house manufacturing and quality.

### The easiest-to-use vision sensors available.

- Easy, menu-driven, point and click interface.
- Remote TEACH input similar to a photoelectric sensor.
- Simple inspection changeovers.
- Live video display without a PC.
- User interface software that allows setup and seamless operation in nine languages.

### The best vision sensor performance.

- Inspection speeds faster than 10,000 parts per minute.
- Full 360° fixture-free inspection.
- Locates inspection detail, regardless of orientation.
- Solves the most applications in your plant.
- Full suite of grayscale, color and binary vision tools.

### More sensors, more solutions, more customer support.

- Superior vision products from the leader in sensing.
- More than 17,000 photoelectric, ultrasonic and vision sensors available worldwide.
- Experienced factory application engineers to solve your most advanced sensing challenges.
- More than 3,000 trained factory and field representatives worldwide.
- Complete factory training, field training and online training.
- Helps you achieve 100% quality inspection and zero defect manufacturing.



*"The substantially lower cost of the Banner vision sensor makes it feasible to set up more inspection systems."*

—Major automotive manufacturer

*"One of the most beneficial, yet simple, advantages of the Banner vision sensor was its TEACH tool. This tool was extremely valuable for eliminating guess work and applying the statistical variation."*

—Automotive engineer

*"The PresencePLUS® vision sensor not only saved time and freed up our quarantined product, it provided a level of documentation."*

—Metal stampings manufacturer

*"I appreciate the level of expertise the field rep showed with the PresencePLUS sensors and how he has helped me with other difficult applications in the past."*

—Major consumer goods manufacturer





## Machine vision made simple.

### **Robust inspection solutions. With more advanced capabilities.**

From simple verification to complex inspection, Banner has the most powerful and affordable vision systems and sensors, built to perform in high-speed manufacturing and production environments. Banner provides an alternative to costly, complex machine vision systems with proven, easy-to-use and affordable self-contained vision sensors for real-world applications.

Select the *PresencePLUS® Pro* which incorporates remote cameras paired with powerful controller units featuring 11 location, vision and analysis tools. Or, choose the versatile new, self-contained *PresencePLUS*

*P4 OMNI* with easy TEACH setup. To deploy the precise inspection capability where you need it, select from four *PresencePLUS P4* series vision sensors with dedicated functionality.

Banner machine vision solutions are available in standard resolution and high-resolution 1.3 megapixel models for more detailed inspections, as well as sealed, IP68-rated models for rugged industrial and washdown environments. *P4* models are available in both in-line and right-angle configurations. These options, as well as a complete selection of Banner lenses, lighting and brackets, provide complete, high-speed inspection capabilities in the vast majority of applications.

## Banner Machine Vision

EXAMPLE APPLICATIONS





**Add inspection capabilities where you need them.** *PresencePLUS® Pro* and *P4* vision sensors integrate easily into existing production systems to provide new levels of quality control, error proofing and verification.

#### **Vial Fill Level and Cap Seal Verification**

To rapidly verify that vials are filled to the correct level and that caps are correctly aligned, a high-speed *PresencePLUS P4* EDGE vision sensor locates the vial and verifies the fill level and cap placement.

#### **Food Packaging Error Proofing**

Each unit of pastry dough is inspected by a *PresencePLUS P4* AREA vision sensor to detect the presence of a frosting packet—ensuring that one is included in each package.

#### **Rivet Inspection**

Following installation of a rivet into each corner of an automobile steering wheel horn frame assembly, the component passes beneath a *PresencePLUS Pro* vision sensor to verify the presence and quality of each rivet.

#### **Gum Wedge Inspection**

A high-resolution *PresencePLUS P4* EDGE 1.3 vision sensor combines with a laser line to inspect the beveled gum wedge of continuously extruded rubber. The laser line bends at the bevel, allowing a cost-effective two-dimensional vision sensor to perform a three-dimensional measurement.

#### **Stamped Metal Pin Inspection**

To verify the quantity, pitch and straightness of connector pins on a stamped metal subassembly, the high-resolution *PresencePLUS P4* OMNI 1.3 vision sensor counts the number of connector pins, simultaneously detecting irregular gaps that indicate pins are bent or missing.

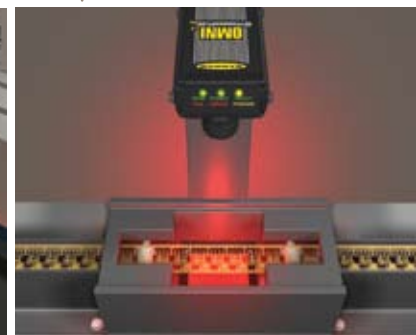
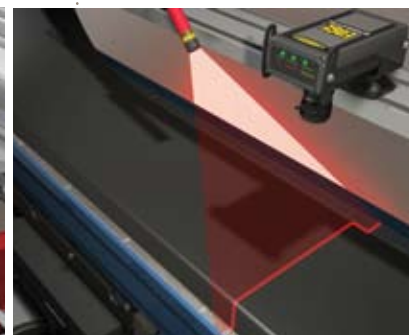
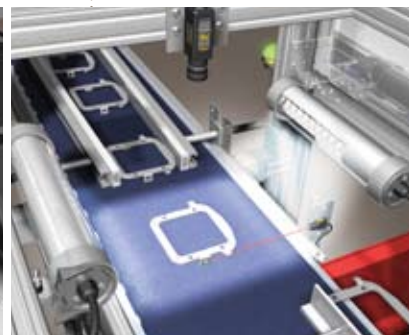





**Color Vision Sophistication. Banner Simplicity.** Banner's PresencePLUS® Pro COLOR and P4 COLOR vision sensors combine with the comprehensive suite of PresencePLUS inspection tools to deliver an easy-to-apply, color-based vision inspection solution of extraordinary sophistication for significantly less than comparable systems.



## Unlimited color spectrum analysis for your most challenging applications.

For inspection features best examined by spectral analysis, Banner offers solutions designed to meet your requirements and fit your machinery. The new one-piece *PresencePLUS® P4 COLOR OMNI* and the compact *PresencePLUS® Pro COLOR* sensor with a separate DIN-mountable controller offer two powerful platforms for color vision applications—with all of the robust inspection tools and capabilities of their gray scale counterparts.

*PresencePLUS Pro COLOR* and *P4 COLOR OMNI* vision sensors inspect unlimited color variations visible in the camera's field of view. Shape and color data can be combined to identify minute variations and color consistency can be monitored within a taught range of acceptable color.

Combining intuitive *PresencePLUS* software, remote TEACH for rapid configuration and a precision 752 x 480 pixel resolution color CMOS imager, *PresencePLUS Pro COLOR* and *P4 COLOR OMNI* vision sensors inspect for a specific color or color range taught to the sensor with the Color Match tool. All models include the powerful suite of gray scale vision tools—including Locate, Pattern Find and Count, Geometric Find and Count, Edge, Object, Blob and Average Gray Scale—that deliver extraordinary precision and versatility, for the most demanding inspections.

### Candy Color Inspection

A *PresencePLUS P4 COLOR OMNI* mounted above a conveyor inspects each box of 12 chocolates, making sure each paper nest contains the correct type, based on color. It rejects boxes that have the wrong chocolate in a nest, are missing product or have damaged product.

### Color Inspection and Verification

A *PresencePLUS Pro COLOR* vision sensor verifies that pour spouts inserted into detergent bottles are present, fully inserted and of the correct color to match the bottle. The IP68 sealed housing protects the sensor and light from liquids.

### Automotive Fuse Box Error Proofing

To verify that fuses of the specified amperage are placed in the correct location in an automotive fuse box assembly, a *PresencePLUS Pro COLOR* vision sensor using a Banner White Area Light provides fast and easy error proofing.

### Comprehensive Blister Pack Inspection

Tightened federal regulations require critical quality controls in pharmaceutical packaging. A *PresencePLUS Pro COLOR* vision sensor under a Banner Tubular Fluorescent Light inspects blister packs to ensure each blister contains the correct tablet, verifies each tablet is unbroken, and detects empty blisters or those containing foreign matter.

### Cap and Fill Inspection

As glass bottles pass on a high-speed conveyor, a *PresencePLUS P4 COLOR OMNI* confirms each bottle is completely filled, while verifying the stopper is fully inserted and is the correct color. Dual Banner Area Lights bracket directly to the sensor to create the optimum contrast for the inspection.

## EXAMPLE APPLICATIONS



## EXAMPLE APPLICATIONS



## Accurately reads and grades 2D and 1D bar codes.

A traceability program is only as successful as the vision sensor that reads 2D or 1D bar codes under plant conditions. That's why major manufacturers depend on the industry's most reliable sensor expert for their vision needs. Banner's *PresencePLUS® Pro* and *P4 OMNI* with optional bar code reading software offer tremendous power and flexibility, for accurate high-speed bar code reading in the toughest environments. The *PresencePLUS® P4 BCR* and high-resolution BCR 1.3 vision sensors have been developed from the ground up for the most robust 2D and 1D linear bar code reading capabilities—even when conditions and codes are less than ideal.

Whether for production traceability of direct-marked manufactured components or to verify product lots for consumer goods, Banner *PresencePLUS* sensors are engineered to offer the highest read rates in low contrast/poor visibility conditions, or where marked or formed bar codes have degraded. The BCR is “taught” the correct codes, either with the sensor itself or over an industrial Ethernet network (EIP or Modbus TCP/IP). Banner's dedicated BCR solutions keep lines moving by reading despite problems such as low contrast, shadows, orientation, surface variations or marking variables resulting from degraded etching, stamping or printing.

BCR models read 2D Data Matrix ECC200 and 1D linear bar codes such as Code 39, Code 128, Codabar, Interleaved 2 of 5, EAN-8 and EAN-13 (supports UPC-A), UPC-E and Postnet. High-resolution BCR 1.3 models (1280 x 1024 pixels) feature 1.3 megapixel imaging that reads and grades smaller bar codes, or allows larger fields of view. Codes and code grades can be communicated using the BCR's serial port.

### 2D Stamped Bar Code Verification

Manufacturing lots can be tracked for quality assurance using a *PresencePLUS Pro* bar code reader to detect and verify a subtle 2D bar code stamped into metal parts. Advanced 2D capabilities and a Banner Low-Angle Ring Light facilitate detection of bar codes subject to stamping quality variables.

### Simultaneous Verification of Two Bar Codes

The high-resolution *PresencePLUS P4 BCR 1.3* delivers an extended field of view to read 1D linear and 2D bar codes simultaneously to verify components in an assembly are correctly paired. Strobed ring lighting and 1.3 megapixel resolution provide increased image repeat rates for accurate reading at full line speed.

### Large Area Verification for Sorting and Die Protection

The dies in tire presses suffer costly damage if the press tries to stamp tread into an unstamped, or green, tire of the wrong size. To direct each tire to the correct press at production line speeds, a series of six high-resolution *PresencePLUS P4 BCR 1.3* vision sensors sort green tires based on bar code data printed on a label on the tire's bead, regardless of position or orientation.

### Miniature Bar Code Verification

The advanced functionality of the *PresencePLUS P4 BCR* reads and verifies miniaturized symbology, such as 2D bar codes, on small electronic components. A Banner Backlight through the semi-transparent circuit membrane optimizes contrast of the code for optimal reading conditions at high line speeds.

### Pharmaceutical Product ID and Lot Control

Federal pharmaceutical product identification and lot control requirements are both stringent and evolving. The *PresencePLUS Pro* gives you the power and flexibility to future-proof inspection, verification and tracking capabilities.







**Part traceability using direct-marked 2D Data Matrix bar codes** demands extraordinary levels of reliable performance from code reading tools. With a proven foundation of industrial sensor reliability, Banner's *PresencePLUS*® P4 BCR sensors handle the toughest 2D and 1D bar code reading chores at the highest throughput rates.





**Setting up an application is easy.** Advanced *PresencePLUS*® software offers point-and-click setup without any knowledge of programming languages. Set up an inspection by simply illuminating the target, focusing the camera and selecting the features to analyze.



## Powerful Inspection Tools. One Advanced Software Platform.

Fulfilling the capabilities of powerful *PresencePLUS*® vision sensor hardware requires an equally advanced software solution. One that operates seamlessly across all Banner vision products. One that provides a common, intuitive graphical interface. One so advanced, it can literally teach itself your vision challenge.

Banner's versatile *PresencePLUS* software does just that. Now configuring sophisticated vision applications is faster and easier than ever before, while common applications are virtually plug-and-play.

### Features:

- Seamless functionality across the entire *Pro* and *P4* vision sensor series.
- Remote TEACH input similar to a photoelectric sensor self-learns the inspection tolerances of your application.
- Easy, menu-driven, point-and-click interface on a PC.
- Simple push-button inspection changeovers.
- Live video display without a PC.
- ActiveX utilities for exporting inspections, images and results.
- Direct connectivity to EtherNet/IP and Modbus TCP industrial networks.
- In nine languages including English, Simplified Chinese, Traditional Chinese, French, German, Japanese, Portuguese and Spanish with translated text, buttons, commands and icons in the respective language.
- Operates on Microsoft Windows® operating systems.
- Free web download or CD-ROM; includes all Banner vision sensor manuals, troubleshooting guides, and lens and lighting selection guides.
- Free firmware and software upgrades.

### PresencePLUS Software Operation

**3-point click-and-go** Intuitive, wizard-like graphics walk the operator through adjusting the sensor position, selecting the features to inspect, operating the sensor and monitoring its outputs.

**Setup** Dynamically view the sensor image, adjust the lighting position and intensity, and then focus the lens to maximize contrast between target features and the background.

**Tools** Highlight the features to inspect while selecting tools and filters to maximize robust operation. Choose criteria and margins for good or failed outputs. Select data or images to communicate through the Ethernet or serial ports.

**Run** Operate inspections and sensor outputs while viewing images or exploring the detailed, comprehensive inspection results. Select the inspection to run. Log any inspection to archive its images and results.

**LOCATION TOOLS** *compensate for translational and rotational movement.*



**Locate** Determines translation and rotation by detecting relative movement of edges



**Pattern Find** Determines translation and rotation by detecting relative movement of a pattern



**GEO Find** Determines translation and rotation movement of a part up to 360° by detecting relative movement of a pattern

**VISION TOOLS** *analyze the image.*



**Color Match** Inspects for matching hue and intensity



**Average Gray Scale** Determines the gray scale intensity value of an area



**Blob** Determines the presence, connectivity, size and location of selected features



**Edge** Determines the presence, number, classification and location of edges



**Object** Determines the presence, number, classification, size and location of objects



**Pattern Count** Determines the presence, number and location of pattern(s)



**GEO Count** Detects the presence and location of a target pattern in any orientation



**Bar Code** Finds, decodes and grades advanced 2D and 1D linear bar codes

**ANALYSIS TOOLS** *measure and evaluate the results of the vision tools.*



**Measure** Measures distance and angles between two prescribed points or lines



**Math** Performs arithmetic functions on any tool or constant



**Test** Evaluates results of selected vision and analysis tools to determine whether an inspection passes or fails; performs logical operations; and activates outputs



**Communication** Sends image or results of selected location, vision and analysis tools over the Ethernet or RS-232 serial communication ports to industrial Ethernet or PC networks

# PresencePLUS® Pro & P4 General-Purpose Sensors



	PROII	PROII 1.3	IP68 PROII	IP68 PROII 1.3	OMNI	OMNI 1.3
<b>Hardware</b>	Page 20				Page 22	
Integrated I/O	14	14	14	14	7	7
Interchangeable Lenses	C-mount	C-mount	C-mount	C-mount	C-mount	C-mount
Interchangeable Lighting	✓	✓	✓	✓	✓	✓
Imager	CCD	CMOS	CCD	CMOS	CCD	CMOS
Resolution	640 x 480	1280 x 1024	640 x 480	1280 x 1024	640 x 480	1280 x 1024
Imager Speed	48 fps	18 fps	48 fps	18 fps	48 fps	27 fps
Color Models	✓		✓		✓	
Live Video Output	✓	✓	✓	✓	✓	✓
Power Requirements	10-30V dc	10-30V dc	10-30V dc	10-30V dc	10-30V dc	10-30V dc
Trigger	Internal or External	Internal or External	Internal or External	Internal or External	Internal or External	Internal or External
Memory	64 MB	64 MB	64 MB	64 MB	32 MB	32 MB
Inspection Storage (Max.)	999	999	999	999	999	999
<b>Communications</b>						
Ethernet	10/100	10/100	10/100	10/100	10/100	10/100
Serial	RS-232	RS-232	RS-232	RS-232	RS-232	RS-232
Programmable Discrete I/O	6	6	6	6	4	4
<b>Programming/Interface</b>						
User Interface Languages Supported <small>(English, German, Japanese, Chinese, Spanish, French, Italian, Portugese)</small>	9	9	9	9	9	9
Industrial Ethernet Protocols	EthnerNet/IP & Modbus TCP/IP	EthnerNet/IP & Modbus TCP/IP	EthnerNet/IP & Modbus TCP/IP	EthnerNet/IP & Modbus TCP/IP	EthnerNet/IP & Modbus TCP/IP	EthnerNet/IP & Modbus TCP/IP
Software Upgrades	Free	Free	Free	Free	Free	Free
Runs without a PC	Yes	Yes	Yes	Yes	Yes	Yes
ActiveX Interface	✓	✓	✓	✓	✓	✓
Quick TEACH	✓	✓	✓	✓	✓	✓
Remote Teach	✓	✓	✓	✓	✓	✓
External Inspection Storage & Operations	✓	✓	✓	✓	✓	✓

▶ **COMMON** **User Interface** <sup>9 Languages</sup> across all Banner Vision products



# PresencePLUS® P4 Dedicated-Function Sensors



AREA	AREA 1.3	EDGE	EDGE 1.3	GEO	GEO 1.3	BCR	BCR 1.3
Page 23							
7	7	7	7	7	7	7	7
C-mount	C-mount	C-mount	C-mount	C-mount	C-mount	C-mount	C-mount
✓	✓	✓	✓	✓	✓	✓	✓
CMOS	CMOS	CMOS	CMOS	CMOS	CMOS	CCD	CMOS
128 x 100	1280 x 1024	128 x 100	1280 x 1024	128 x 100	1280 x 1024	640 x 480	1280 x 1024
500 fps	27 fps	500 fps	27 fps	500 fps	27 fps	48 fps	27 fps
✓	✓	✓	✓	✓	✓	✓	✓
10-30V dc	10-30V dc	10-30V dc	10-30V dc	10-30V dc	10-30V dc	10-30V dc	10-30V dc
Internal or External	Internal or External	Internal or External	Internal or External	Internal or External	Internal or External	Internal or External	Internal or External
8 MB	32 MB	8 MB	32 MB	8 MB	32 MB	8 MB	32 MB
500	999	500	999	500	999	400	999
10/100	10/100	10/100	10/100	10/100	10/100	10/100	10/100
RS-232	RS-232	RS-232	RS-232	RS-232	RS-232	RS-232	RS-232
4	4	4	4	4	4	4	4
9	9	9	9	9	9	9	9
EthnerNet/IP & Modbus TCP/IP	EthnerNet/IP & Modbus TCP/IP	EthnerNet/IP & Modbus TCP/IP	EthnerNet/IP & Modbus TCP/IP	EthnerNet/IP & Modbus TCP/IP	EthnerNet/IP & Modbus TCP/IP	EthnerNet/IP & Modbus TCP/IP	EthnerNet/IP & Modbus TCP/IP
Free	Free	Free	Free	Free	Free	Free	Free
Yes	Yes	Yes	Yes	Yes	Yes	Yes	Yes
✓	✓	✓	✓	✓	✓	✓	✓
✓	✓	✓	✓	✓	✓	✓	✓
✓	✓	✓	✓	✓	✓	✓	✓
✓	✓	✓	✓	✓	✓	✓	✓

▶ **FREE** Software & Firmware **UPGRADES**

# Pro and P4 General-Purpose Sensors

**Affordable full-feature vision sensor solutions.  
No compromises.**

## PresencePLUS® Pro Series

- Full-featured; compact camera with separate DIN-mountable controller
- Convenient 20-pin removable terminal block
- Six bicolor bright LED indicators
- Fourteen configurable discrete I/O (NPN/PNP)



### PROII Models

*PresencePLUS Pro*

640 X 480 resolution CCD

*PresencePLUS Pro COLOR*

752 X 480 resolution CMOS

*PresencePLUS Pro 1.3*

1280 X 1024 resolution CMOS

*PresencePLUS Pro sealed cameras*

Rugged, IP68 housing

The *PresencePLUS® Pro* and *PresencePLUS® P4 OMNI* vision sensors deliver professional, image-based inspection capabilities to your factory floor—at an unprecedented price. Banner has transformed costly, complex machine vision systems into easy-to-use, workhorse sensors that solve real-world applications. Now you can quickly integrate inspection capabilities anywhere you need them, at a cost that's easy to justify and provides immediate ROI. Banner innovation has revolutionized vision inspection by consolidating a host of powerful features into two advanced hardware platforms, available in standard, color, high-resolution and IP68 sealed models.

## PresencePLUS Series Features:

- Universal software with three-step, point-and-click setup.
- Ethernet, serial and flexible discrete I/O in the same full-featured sensor.
- Direct connectivity for all I/O to EtherNet/IP and Modbus TCP.
- ActiveX connectivity to create custom operator control software with object-oriented programming.
- Real-time video output for direct connection to a conventional monitor without a PC.
- Remote and Quick TEACH with a single reference image or custom setup.
- Color, IP68 housing and high-resolution 1.3 megapixel models.
- Complete suite of location, inspection, analysis and geometric tools; all can be used simultaneously for inspecting multiple features and complex applications.
- Multiple inspection routines, stored and accessed without a PC.
- Microsoft Windows® compatible OS with intuitive Wizard-like setup procedure and common graphical interface; supports nine languages.
- Complete selection of lenses, lighting, brackets and accessories.
- 10 to 30V dc operation.

## PresencePLUS® P4 OMNI Series

- Full featured; economical one-piece design
- Seven configurable discrete I/O (NPN/PNP)
- Three bicolor bright LED indicators
- In-line or right-angle housing



### P4 OMNI Models

*PresencePLUS P4 OMNI*

640 X 480 resolution CCD

*PresencePLUS P4 OMNI COLOR*

752 X 480 resolution CMOS

*PresencePLUS P4 OMNI 1.3*

1280 X 1024 resolution CMOS







**Comprehensive vision capabilities** in an affordable, easy-to-use sensor. Banner's PresencePLUS® general-purpose vision sensors offer location, vision and analysis tools that can be used together to solve nearly any inspection challenge.





**Solve specific inspection challenges.** Banner's PresencePLUS® P4 series of dedicated-function vision sensors delivers the performance and ease of use you need in a affordable, practical solution for any size manufacturer.



## Robust, affordable vision solutions solve specific inspection challenges.

In the past, machine vision was practical only for complex, mission-critical inspection applications at considerable expense. Banner's *PresencePLUS*® vision sensors changed everything, bringing high-performance inspection capabilities with ease-of-use and affordability—priced for general industry. Now, Banner revolutionizes vision again, with a family of four powerful, affordable vision sensors dedicated to solving the most common inspection challenges. *PresencePLUS*® P4 series dedicated-function sensors offer just the tools you need, in a price-performance breakthrough that simplifies vision inspection and makes it practical.

### ***PresencePLUS* P4 Dedicated-Function Sensors:**

- Four models with Locate, Measure, Math, Test, Communications and specific vision tools
- High-performance vision inspections in self-contained in-line or right-angle housing styles that fit in the palm of your hand
- Standardized GUI supports nine languages
- Remote TEACH function for inspection changeovers without a PC
- Connects directly to real-time video display without a PC
- Communicates over Ethernet, configurable discrete I/O and RS-232 serial lines
- Provides direct connectivity to EtherNet/IP and Modbus TCP industrial networks
- ActiveX utilities for custom operator controls
- Available with a variety of mounting brackets, lenses and lighting accessories

### ***PresencePLUS* P4 AREA and AREA 1.3:**

- Inspects presence and size of defined areas using Blob and Gray Scale tools to capture and analyze images and render pass-fail judgements
- Ideal for high-speed quality control, such as sorting, assembly error proofing, feature identification and counting, orientation confirmation, process control, complete case inspection and flaw detection

### ***PresencePLUS* P4 GEO and GEO 1.3:**

- Performs 360° fixture-free inspections using GEO Count tool to detect the presence and location of a pattern, regardless of product orientation or position in the sensor's field of view
- Ideal for part identification and orientation, pre-packaging assembly verification, error proofing and label verification

### ***PresencePLUS* P4 EDGE and EDGE 1.3:**

- Measures multiple edges of a product using Edge and Object tools to gauge height, width, location and edges of selected areas
- Ideal for part identification and orientation, assembly verification, error proofing, label verification, quality control sorting and measuring applications

### ***PresencePLUS* P4 BCR and BCR 1.3:**

- Reads and decodes 2D and 1D linear bar codes; grades codes using industry standard metrics
- Reads Data Matrix (ECC200) and standard linear codes including Code 39, Code 128, Codabar, Interleaved 2 of 5, EAN-8, EAN-13 (supports UPC-A), UPC-E and Postnet
- High-resolution model reads and grades smaller bar codes in larger fields of view



***PresencePLUS* P4 AREA**

- Uses Blob and Gray Scale tools for basic inspections of defined areas
- High-speed analysis up to 10,000 parts per minute
- Standard resolution: 128 X 100
- High-resolution: 1280 X 1024



***PresencePLUS* P4 GEO**

- Uses GEO Count tool to detect presence, location and rotation of a target pattern (360°)
- Standard resolution: 128 X 100
- High-resolution: 1280 X 1024



***PresencePLUS* P4 EDGE**

- Uses Edge and Object tools to validate height, width, location and edges
- High-speed analysis faster than 10,000 parts per minute
- Standard resolution: 128 X 100
- High-resolution: 1280 X 1024



***PresencePLUS* P4 BCR**

- Finds and decodes 2D and 1D linear bar codes
- Industry standard bar code metrics and grading
- Standard resolution: 640 X 480
- High-resolution: 1280 X 1024



## PresencePLUS® Pro Sensors

- A full-featured vision sensor for advanced inspections
- Compact camera with separate DIN mountable controller
- A complete suite of location, inspection, analysis and geometric tools
- Color, IP68 housing and high-resolution models

### Controllers

Model Number:	PPROCTL	PPROCTLBCR	PPROCTL1.3	PPROCTL1.3BCR	PPROCTLC	PPROCTLCBCR
Vision Tools:	PROII Gray Scale	PROII Gray Scale with Bar Code	PROII Gray Scale	PROII Gray Scale with Bar Code	COLOR PROII	COLOR PROII with Bar Code
Resolution:	640 x 480		1280 x 1024		752 x 480	

	Cameras	Model Number	Model Number	Model Number	Ring Light	Window
<b>Pro Cameras</b>		PPROCAM	PPROCAM1.3	PPROCAMC	—	—
	<b>Sealed Pro Cameras</b>		PPROCAMSC-G	PPROCAM1.3SC-G	PPROCAMCSC-G	Cover (No Light)
		PPROCAMSC-P	PPROCAM1.3SC-P	PPROCAMCSC-P	Plastic	
		PPROCAMSR-G	PPROCAM1.3SR-G	—	Red	Glass
		PPROCAMSR-P	PPROCAM1.3SR-P			Plastic
		PPROCAMSI-G	PPROCAM1.3SI-G	—	Infrared	Glass
		PPROCAMSI-P	PPROCAM1.3SI-P			Plastic
		PPROCAMSB-G	PPROCAM1.3SB-G	—	Blue	Glass
		PPROCAMSB-P	PPROCAM1.3SB-P			Plastic
		PPROCAMSG-G	PPROCAM1.3SG-G	—	Green	Glass
		PPROCAMSG-P	PPROCAM1.3SG-P			Plastic
		PPROCAMSW-G	PPROCAM1.3SW-G	PPROCAMCSW-G	White	Glass
		PPROCAMSW-P	PPROCAM1.3SW-P	PPROCAMCSW-P		Plastic

## Pro Basic Kit Model Key

Basic kits include a controller, camera, camera-to-controller cordset, CD-ROM and quick start guide.

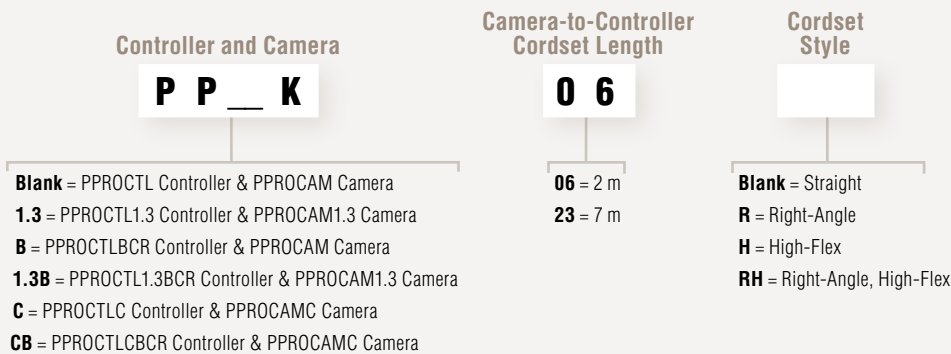

## Sealed Pro Basic Kit Model Key

Basic kits include a controller, sealed camera with cover or ring light, camera, camera-to-controller cordset, ring light power cable, CD-ROM and quick start guide.

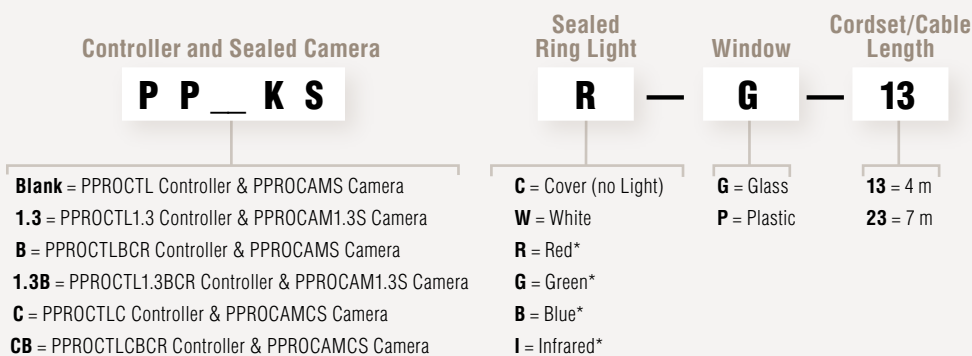

\* Not recommended for color applications















## PresencePLUS® P4 General-Purpose Sensors

- Full-featured vision sensors for advanced inspections
- One-piece in-line or right-angle housings
- Color and high-resolution models

### P4 Sensors with OMNI Tool Set

Model Number	Vision Tools	Housing	Resolution
 <b>P40R</b>	OMNI Gray Scale	Right-Angle	640 x 480
 <b>P40I</b>		In-Line	
 <b>P401.3R</b>		Right-Angle	1280 x 1024
 <b>P401.3I</b>		In-Line	
 <b>P40BR</b>	OMNI Gray Scale with Bar Code	Right-Angle	640 x 480
 <b>P40BI</b>		In-Line	1280 x 1024
 <b>P401.3BR</b>		Right-Angle	
 <b>P401.3BI</b>		In-Line	
 <b>P4COR</b>	COLOR OMNI	Right-Angle	752 x 480
 <b>P4COI</b>		In-Line	
 <b>P4COBR</b>	COLOR OMNI with Bar Code	Right-Angle	752 x 480
 <b>P4COBI</b>		In-Line	

### P4 with OMNI Tool Set Basic Kits

Basic kits include a sensor, bracket, cable, CD-ROM and quick start guide.

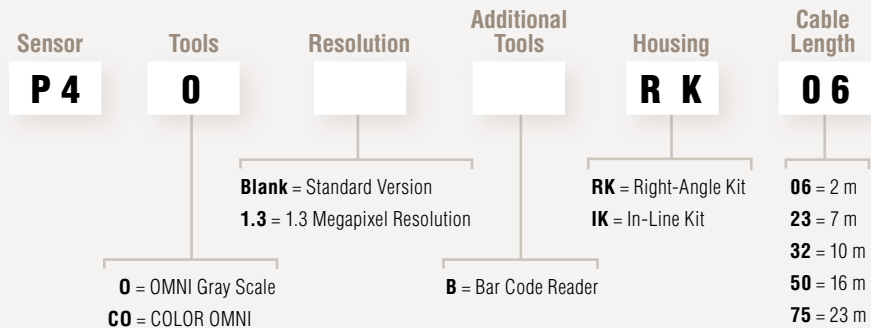

# PresencePLUS® P4 Dedicated-Function Sensors

- Family of four vision sensors for specific inspection challenges
- One-piece in-line or right-angle housings
- High-resolution 1.3 megapixel models for more detailed inspections and increased field of view



## P4 Sensors with Simplified Tool Set

Model Number	Vision Tools	Housing	Resolution
	AREA Blob & Gray Scale	Right-Angle	128 x 100
		In-Line	
		Right-Angle	1280 x 1024
		In-Line	
	GEO Count & Find	Right-Angle	128 x 100
		In-Line	1280 x 1024
		Right-Angle	
		In-Line	
	EDGE Edge & Object	Right-Angle	128 x 100
		In-Line	1280 x 1024
		Right-Angle	
		In-Line	
	BCR Bar Code Reader	Right-Angle	640 x 480
		In-Line	1280 x 1024
		Right-Angle	
		In-Line	

## P4 with Simplified Tool Set Basic Kits

Basic kits include a sensor, bracket, cable, CD-ROM and quick start guide.

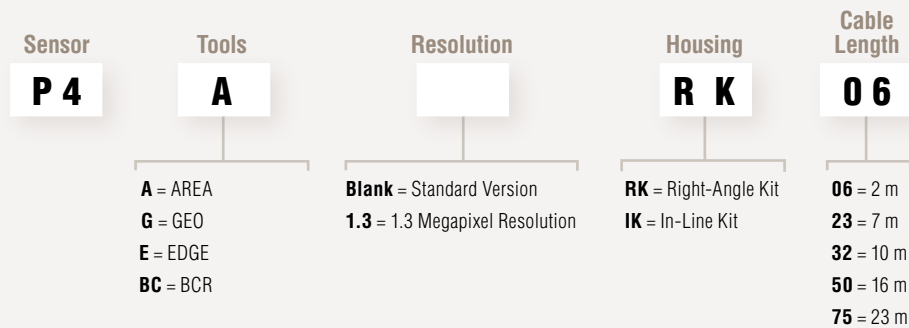





## PresencePLUS<sup>®</sup> Pro Specifications

PresencePLUS <sup>®</sup> Pro Controller Specifications	
<b>Supply Voltage and Current</b>	<b>PPROCTL &amp; PPROCTLBCR:</b> 10 to 30V dc @ less than 1.5 A (exclusive of load) <b>PPROCTL1.3, PPROCTL1.3BCR, PPROCTL &amp; PPROCTLBCR:</b> 10 to 30V dc @ less than 1.2 A (exclusive of load)
<b>Supply Protection Circuitry</b>	Protected against reverse polarity and transient voltages
<b>Memory</b>	<b>Storage:</b> 64 MB <b>Inspections (jobs):</b> 999 max.
<b>Input/Output Configuration</b>	NPN (sinking) or PNP (sourcing) software selectable
<b>Output Rating</b>	150 mA max. each output <b>OFF-state leakage current:</b> less than 100 $\mu$ A <b>ON-state saturation voltage:</b> <b>NPN</b> —less than 1V @ 150 mA <b>PNP</b> —greater than $V_+ - 2V$
<b>Input Specifications</b>	<b>NPN: ON</b> —less than 3V <b>OFF-state voltage</b> —greater than 10V @ 4 mA max. <b>PNP: ON</b> —greater than (+V-2)V @ 1 mA max. <b>OFF-state voltage</b> —less than 3V @ 6 mA max.
<b>Indicators</b>	<b>6 LED indicators:</b> Trigger, Ready, Power, Pass, Fail, Error
<b>Display Options</b>	PC or NTSC video (uses 9 m max. BNC cable)
<b>Discrete I/O</b>	1 Trigger IN (pin 3), 1 Strobe OUT (pin 4), 1 Remote TEACH IN (pin 6), 6 Programmable I/O (pins 9-14) 1 Product Change IN (pin 15), 4 Product Select IN (pins 16-19)
<b>Communications</b>	1 RJ-45 Ethernet-connection for running <i>PresencePLUS Pro</i> software and/or output inspection results 1 RS-232 DB-9 port for running <i>PresencePLUS Pro</i> software and/or output inspection results
<b>Construction</b>	Steel with black zinc plating
<b>Weight</b>	0.55 kg
<b>Environmental Rating</b>	IEC IP20; NEMA 1
<b>Operating Temperature</b>	0° to +50° C
<b>Relative Humidity</b>	90% (non-condensing)

PresencePLUS <sup>®</sup> Pro Camera Specifications	
<b>Imager Resolution</b>	<b>PPROCAM &amp; PPROCAMS:</b> 640 x 480 pixels <b>PPROCAM1.3 &amp; PPROCAM1.3S:</b> 1280 x 1024 pixels <b>PPROCAMC &amp; PPROCAMCS:</b> 752 x 480 pixels
<b>Pixel Size</b>	<b>PPROCAM &amp; PPROCAMS:</b> 7.4 x 7.4 $\mu$ m <b>PPROCAM1.3 &amp; PPROCAM1.3S:</b> 6.7 x 6.7 $\mu$ m <b>PPROCAMC &amp; PPROCAMCS:</b> 6.0 x 6.0 $\mu$ m
<b>Imager Size</b>	<b>PPROCAM &amp; PPROCAMS:</b> 4.8 x 3.6 mm, 6 mm diagonal (1/3 inch CCD) <b>PPROCAM1.3 &amp; PPROCAM1.3S:</b> 8.6 x 6.9 mm, 11 mm diagonal (2/3 inch CMOS) <b>PPROCAMC &amp; PPROCAMCS:</b> 4.5 x 2.9 mm, 5.4 mm diagonal (1/3 inch CMOS)
<b>Levels of Gray Scale or Color</b>	<b>PPROCAM, PPROCAM1.3, PPROCAMS &amp; PPROCAM1.3S:</b> 256 Grayscale <b>PPROCAMC &amp; PPROCAMCS:</b> 256 Red, Green and Blue
<b>Exposure Time</b>	<b>PPROCAM &amp; PPROCAMS:</b> 0.10 to 2830 milliseconds <b>PPROCAM1.3 &amp; PPROCAM1.3S:</b> 0.10 to 1670 milliseconds <b>PPROCAMC &amp; PPROCAMCS:</b> 0.10 to 1040 milliseconds
<b>Acquisition</b>	<b>PPROCAM &amp; PPROCAMS:</b> 48 frames per second max. <b>PPROCAM1.3 &amp; PPROCAM1.3S:</b> 18 frames per second max. <b>PPROCAMC &amp; PPROCAMCS:</b> 17 frames per second max.
<b>Interface</b>	LVDS
<b>Lens Mount</b>	Standard C-mount (1 inch—32 UN)
<b>Construction</b>	<b>PPROCAM, PPROCAM1.3 &amp; PPROCAMC:</b> black anodized aluminum <b>PPROCAMS, PPROCAM1.3S &amp; PPROCAMCS:</b> nickel-plated aluminum (Lens covers and ring lights are nickel-plated aluminum with glass or polycarbonate window)
<b>Max. Cable Length</b>	7 m
<b>Weight</b>	<b>PPROCAM, PPROCAM1.3 &amp; PPROCAMC:</b> approx. 0.09 kg <b>PPROCAMS, PPROCAM1.3S &amp; PPROCAMCS:</b> approx. 0.28 kg <b>Camera only</b> —0.28 g, <b>Camera with cover</b> —0.35 g, <b>Camera with ring light</b> —0.59 g
<b>Environmental Rating</b>	<b>PPROCAM, PPROCAM1.3 &amp; PPROCAMC:</b> IEC IP20; NEMA 1 <b>PPROCAMS, PPROCAM1.3S &amp; PPROCAMCS:</b> IEC IP68; NEMA 6P
<b>Operating Temperature</b>	0° to +50° C
<b>Relative Humidity</b>	<b>PPROCAM, PPROCAM1.3 &amp; PPROCAMC:</b> 90% (non-condensing)









# PresencePLUS<sup>®</sup> Pro Hookups & Dimensions

## Pro Hookup Diagrams

NPN Outputs with NPN Inputs†

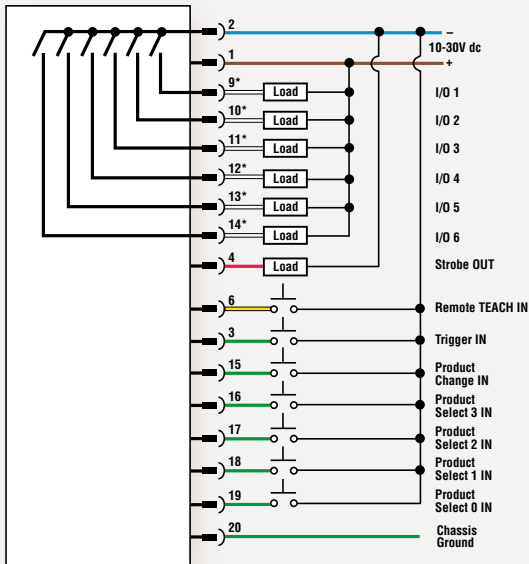

PNP Outputs with PNP Inputs†

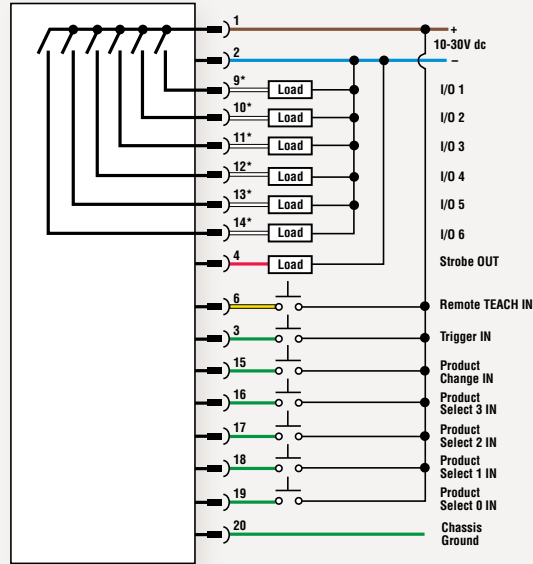

### Key

- 1 = Brown
- 2 = Blue
- 3 = Green
- 4 = Red
- 5 = Yellow\*\*
- 6 = Yellow
- 7 = Yellow\*\*
- 8 = Yellow\*\*
- 9 = White\*
- 10 = White\*
- 11 = White\*
- 12 = White\*
- 13 = White\*
- 14 = White\*
- 15 = Green
- 16 = Green
- 17 = Green
- 18 = Green
- 19 = Green
- 20 = Green

† Inputs can be either NPN or PNP.  
 \* Can be independently configured as an output or input.  
 \*\* Not used

## Connection Points

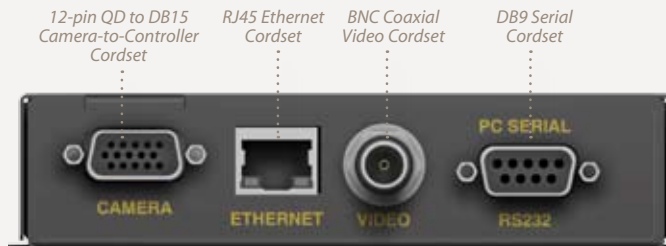

## Terminal Diagram

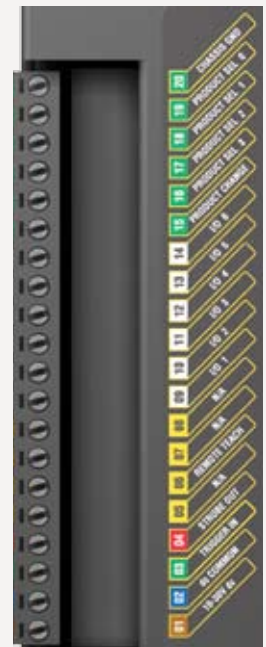

## Dimension Drawings



Detailed Dimensions



Controller Models



Camera Models  
 (Shown with lens—sold separately)



Sealed Camera Models  
 (Shown with cover)

# PresencePLUS® P4 Hookups & Dimensions



## P4 Hookup Diagrams

### NPN Outputs with NPN Inputs†

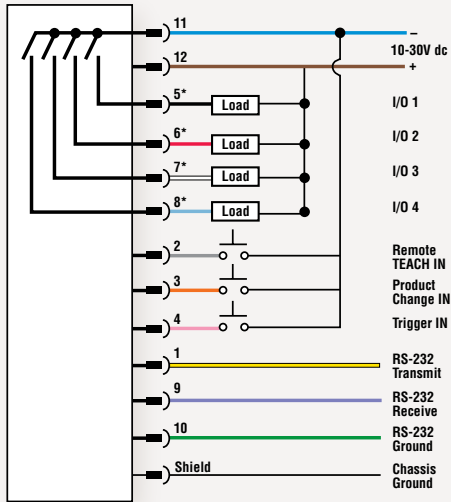

### PNP Outputs with PNP Inputs†

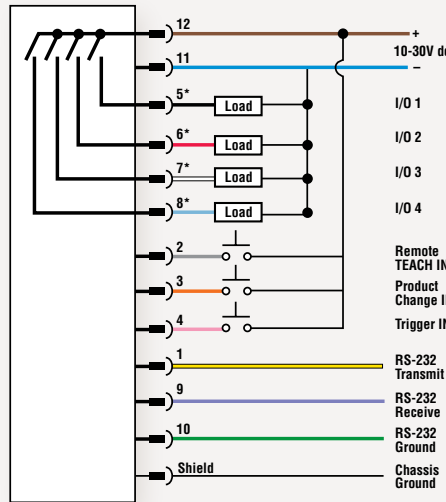

† Inputs can be either NPN or PNP.  
\* Can be independently configured as an output or input.

### Key

- 1 = Yellow
- 2 = Gray
- 3 = Orange
- 4 = Pink
- 5 = Black\*
- 6 = Red\*
- 7 = White\*
- 8 = Light Blue\*
- 9 = Purple
- 10 = Green
- 11 = Blue
- 12 = Brown
- Shield = Bare Metal

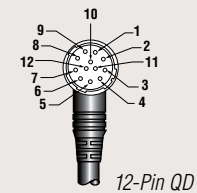

## Connection Points

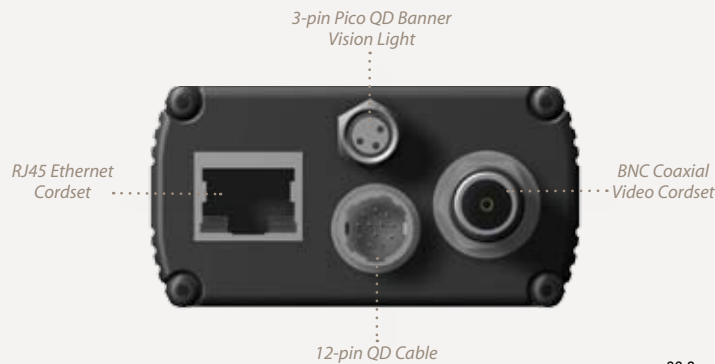

## Dimension Drawings



**Right-Angle Sensor Models**  
(Shown with lens—sold separately)

**In-Line Sensor Models**  
(Shown with lens—sold separately)





### Light

See page 31

- Maintenance free, rugged LED lighting in red, green, blue, white and infrared
- Ring lights, area lights, backlights, on-axis lights and speciality lights for tough-to-light objects
- Models for direct connection to sensors or external power supply

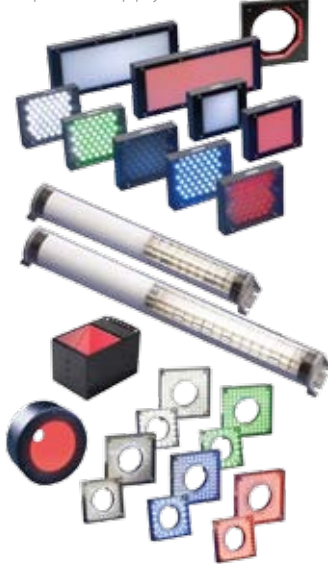

### Lens

See page 39

- 4-75 mm standard C-mount lenses
- 3.5-75 mm high-performance lenses for less image distortion and greater depth of field
- 8-50 mm megapixel lenses for extraordinary resolution
- Focus locking on most models



Classic Yellow® Mustard  
1 00 41500 00700

## Vision Sensing System Selection and Integration. Banner Makes it Easy. And Affordable.

The processing power, sophisticated technology and innovation of compact, affordable Banner *PresencePLUS*® vision sensors make possible high-speed inspection, measurement, sorting and quality control capabilities that were once possible only with sensor arrays or costly, complex machine vision systems. The flexibility and low cost of *PresencePLUS* vision sensors let manufacturers place more sensors in more inspection points to detect defective parts before they become rejected—and costly—assemblies at the end of the production line.

With Ethernet, serial and flexible discrete I/O in every *PresencePLUS* sensor, Windows® based GUI and easy-to-apply inspection tools, integrating a vision system into an existing manufacturing environment no longer requires reconfiguration, wiring runs or significant downtime.

*PresencePLUS P4* dedicated-function vision sensors, with lenses and lighting, economically and effectively solve a host of common inspection, measurement, identification and presence applications with plug-and-play simplicity. High-resolution models offer 1.3 megapixel imaging for more detailed inspections of large areas. For more complex or demanding applications, *PresencePLUS P4 OMNI* and *PresencePLUS Pro* full-feature vision sensors offer additional location, vision and analysis tools and I/O—plus color and sealed models. Combined with lighting options, highest quality optics and versatile fixturing solutions, there is a *PresencePLUS* vision sensor to handle your most demanding applications at a fraction of the cost of a conventional machine vision system.

### Bracket/Enclosure

See page 40

- A wide selection of specialized brackets, fixtures and mounting systems
- Models for *Pro* and *P4* sensors and Banner lighting
- Enclosures for sensors and lights



### Display/Indicators

See page 43

- Live video output for enhanced inspection visibility during setup and/or operation
- Black and white, or color monitors for displaying images
- Indicators for clear indication of part status



### Cable

See page 44

- Cables for sensors, cameras, video, serial and Ethernet connections
- Splitter cable for powering two lights from one *P4* sensor
- High-flex cables for robotic applications



### Interface Module

See page 46

- Simplify wiring of *P4* sensors in an electrical panel
- Provide repeatable control of strobed lights
- Interface between hardware and *PresencePLUS* sensors or lighting







## An Illuminating Look at the Critical Role of Lighting in Successful Vision Sensing.

No matter how powerful or robust a sensor is, successfully meeting challenging vision applications relies heavily on matching the vision sensor with appropriate lighting. Lighting sources, geometry and techniques need to be optimized to the target's optical properties. While contrast is critical, target size, speed, working distance, topography, color, and likelihood of defects are among the other considerations.

The choices in lighting optics, color filters, diffusers and focusing elements are as varied as the choices of light sources, which include LEDs, fluorescents, lasers, and incandescent halogens or xenons. Lighting is essential to any successful vision sensing system.

Fortunately, Banner offers one of the industry's most extensive selection of lighting solutions for vision sensing, plus the knowledge, personnel and experience to create an integrated solution that delivers reliable performance at desired speeds. Banner's lighting selection and accessories provide single-source convenience and support for matching a sensor and illumination. For the most challenging applications, Banner engineers will work with your sample parts to design an integrated optimal solution.

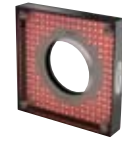

**Ring Light** (see page 32)  
Mounts directly to the sensor for easy setup and illuminates any object directly in front of the sensor



**Backlight** (see page 33)  
Installs behind the target, directly facing the sensor; has a highly diffused surface and uniform brightness, with a lower intensity than other lights

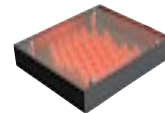

**Area Light** (see page 34)  
Provides even illumination in a concentrated area



**Spot Light** (see page 35)  
Provides even illumination in a small concentrated spot



**Linear Array Light** (see page 35)  
Provides high-intensity illumination of large areas, at long distances



**Tubular Fluorescent Light** (see page 35)  
Features flicker-free high-intensity illumination of large areas



**On-Axis Light** (see page 36)  
Provides collimated illumination in same optical path as camera



**Highly Diffused Light** (see page 36)  
Softly illuminates from multiple directions, minimizing glare and shadows



**Low-Angle Ring Light** (see page 37)  
Illuminates nearly perpendicular to the direction of an inspection, enhancing the contrast of surface features



**Multi-Light** (see page 37)  
Has independently adjustable light intensity on each axis



**Structured Light** (see page 37)  
Uses laser emitter with extra bright light for 3-dimensional sensing

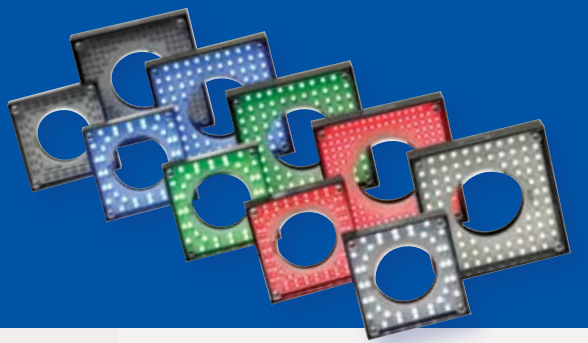

## PresencePLUS® Ring Lights

- Brightly illuminates smaller objects
- Centers the light on the image
- Mounts directly to the camera



### PresencePLUS® Pro LED Ring Lights

Voltage: 24V dc

Size†	Model	Description	Connection*	Data Sheet
80 x 80 mm	LEDRR80X80W	Red	2 m	108626
	LEDWR80X80W	White		
	LEDBR80X80W	Blue		
	LEDGR80X80W	Green		
	LEDIR80X80W	Infrared		
62 x 62 mm	LEDRR62X62W	Red	2 m	108626
	LEDWR62X62W	White		
	LEDBR62X62W	Blue		
	LEDGR62X62W	Green		
	LEDIR62X62W	Infrared		

\*For 9 m cable, add suffix **W/30** to the 2 m model number (example, **LEDRR80X80W W/30**).

† For replacement windows and diffusers (see page 38).



### PresencePLUS® P4 LED Ring Lights

Voltage: 24V dc

Size†	Model	Description	Connection*	Data Sheet
80 x 80 mm	LEDRR80X80M	Red	0.3 m Threaded 3-pin Pico pigtail QD	116941
	LEDWR80X80M	White		
	LEDBR80X80M	Blue		
	LEDGR80X80M	Green		
	LEDIR80X80M	Infrared		
62 x 62 mm	LEDRR62X62M	Red	0.3 m Threaded 3-pin Pico pigtail QD	116941
	LEDWR62X62M	White		
	LEDBR62X62M	Blue		
	LEDGR62X62M	Green		
	LEDIR62X62M	Infrared		

\*Splitter cable available for powering two lights (see page 45).

† For replacement windows and diffusers (see page 38).



### Sealed PresencePLUS® Pro LED Ring Lights

Voltage: 24V dc



Size	Model	Window	Description	Connection	Data Sheet
90 mm dia.	LEDRR90S-P	Plastic	Red	3-pin Pico QD	128842
	LEDRR90S-G	Glass			
	LEDWR90S-P	Plastic	White		
	LEDWR90S-G	Glass			
	LEDBR90S-P	Plastic	Blue		
	LEDBR90S-G	Glass			
	LEDGR90S-P	Plastic	Green		
	LEDGR90S-G	Glass			
	LEDIR90S-P	Plastic	Infrared		
	LEDIR90S-G	Glass			



### Specialty Ring Lights

Size	Model	Description	Data Sheet
100 mm dia.	HFFW5100	110V ac Fluorescent	115969
	HFFW5100A220	220V ac Fluorescent	115970
	HFFBB	110V ac UV Fluorescent	115968

RFLBB UV fluorescent ring lamp replacement bulb, RFLW5100 fluorescent ring lamp replacement bulb.  
NOTE: Specialty lights are not stocked and are non-returnable.





## PresencePLUS® Backlights

- Determines the shape and size of target objects
- Provides the most robust lighting for measuring and gauging
- Highlights through-holes in target objects



### LED Backlights

Voltage: **24V dc**

Illumination Area†	Model	Description	Connection*	Data Sheet
70 x 70 mm	LEDRB70X70W	Red	2 m	115349
	LEDRB70X70M		2 m Threaded 3-pin Pico pigtail QD	116947
	LEDIB70X70W	Infrared	2 m	115349
	LEDIB70X70M		2 m Threaded 3-pin Pico pigtail QD	116947
85 x 220 mm	LEDRB85X220W	Red	2 m	115349
	LEDRB85X220M		2 m Threaded 3-pin Pico pigtail QD	116947
	LEDIB85X220W	Infrared	2 m	115349
	LEDIB85X220M		2 m Threaded 3-pin Pico pigtail QD	116947



\*For 9 m cable, add suffix **W/30** to the 2 m model number (example, **LEDRB70X70W W/30**). QD models can be connected directly to P4 sensors; splitter cables available for powering two lights (see page 45).

† For replacement windows and diffusers (see page 38).

### Specialty LED Backlights

Voltage: **12V dc**

Illumination Area	Model	Description	Connection*	Data Sheet
50 x 50 mm	LEDRB50X50N	Red diffused	1.8 m with 9-pin D-sub connector	67426
	LEDWB50X50N	White diffused		
	LEDBB50X50N	Blue diffused		
	LEDIB50X50N	Infrared diffused		
75 x 75 mm	LEDRB75X75N	Red diffused		67427
	LEDWB75X75N	White diffused		
	LEDBB75X75N	Blue diffused		
	LEDIB75X75N	Infrared diffused		
100 x 100 mm	LEDRB100X100N	Red diffused		67428
	LEDWB100X100N	White diffused		
	LEDBB100X100N	Blue diffused		
	LEDIB100X100N	Infrared diffused		
50 x 200 mm	LEDRB50X200N	Red diffused	67429	
	LEDRB50X200N-H	Red diffused, high output	67430	
	LEDRB50X200N-NH	Red non-diffused, high output		
100 x 200 mm	LEDRB100X200N	Red diffused	67431	
	LEDIB100X200N	Infrared diffused		



\*Specialty lights are not stocked and are non-returnable; they require an external power supply (see page 46).



## PresencePLUS® Area Lights

- Illuminates specific surface angles
- Reflects glare from shiny surfaces away from camera
- Creates shadows to detect changes in depth



### LED Area Lights

Voltage: **24V dc**

Size†	Model	Description	Connection*	Data Sheet
80 x 80 mm	LEDRA80X80W	Red	2 m	115607
	LEDRA80X80M		2 m Threaded 3-pin Pico pigtail QD	116949
	LEDWA80X80W	White	2 m	115607
	LEDWA80X80M		2 m Threaded 3-pin Pico pigtail QD	116949
	LEDBA80X80W	Blue	2 m	115607
	LEDBA80X80M		2 m Threaded 3-pin Pico pigtail QD	116949
	LEDGA80X80W	Green	2 m	115607
	LEDGA80X80M		2 m Threaded 3-pin Pico pigtail QD	116949
	LEDIA80X80W	Infrared	2 m	115607
	LEDIA80X80M		2 m Threaded 3-pin Pico pigtail QD	116949
62 x 62 mm	LEDRA62X62W	Red	2 m	121779
	LEDRA62X62M		2 m Threaded 3-pin Pico pigtail QD	121780
	LEDWA62X62W	White	2 m	121779
	LEDWA62X62M		2 m Threaded 3-pin Pico pigtail QD	121780
	LEDBA62X62W	Blue	2 m	121779
	LEDBA62X62M		2 m Threaded 3-pin Pico pigtail QD	121780
	LEDGA62X62W	Green	2 m	121779
	LEDGA62X62M		2 m Threaded 3-pin Pico pigtail QD	121780
	LEDIA62X62W	Infrared	2 m	121779
	LEDIA62X62M		2 m Threaded 3-pin Pico pigtail QD	121780

\* For 9 m cable, add suffix **W/30** to the 2 m model number (example, **LEDRA80X80W W/30**). QD models can be connected directly to P4 sensors; splitter cables available for powering two lights (see page 45).

† For replacement windows and diffusers (see page 38).

### Specialty LED Area Lights

Voltage: **12V dc**

Size	Model	Description	Connection*	Data Sheet
50 x 50 mm	LEDRA50X50N	Red	1.8 m with 9-pin D-sub connector	67423
	LEDWA50X50N	White		
	LEDBA50X50N	Blue		
	LEDIA50X50N	Infrared		
75 x 75 mm	LEDRA75X75N	Red	1.8 m with 9-pin D-sub connector	67424
	LEDWA75X75N	White		
	LEDBA75X75N	Blue		
	LEDIA75X75N	Infrared		
100 x 100 mm	LEDRA100X100N	Red	1.8 m with 9-pin D-sub connector	67425
	LEDWA100X100N	White		
	LEDBA100X100N	Blue		
	LEDIA100X100N	Infrared		

\*Specialty lights are not stocked and are non-returnable; they require an external power supply (see page 46).

## PresencePLUS® Spot Lights

- Provides off-axis illumination of small areas
- Withstands washdown (rated IP67)



### Sealed LED Spot Lights

Voltage: **10 to 30V dc**

Size	Model	Description	Connection*	Data Sheet
30 mm	<b>LEDRSW</b>	<b>Red</b>	2 m	122987
	<b>LEDRSM</b>		2 m Threaded 3-pin Pico pigtail QD	122986
	<b>LEDWSW</b>	<b>White</b>	2 m	122987
	<b>LEDWSM</b>		2 m Threaded 3-pin Pico pigtail QD	122986
	<b>LEDBSW</b>	<b>Blue</b>	2 m	122987
	<b>LEDBSM</b>		2 m Threaded 3-pin Pico pigtail QD	122986
	<b>LEDGSW</b>	<b>Green</b>	2 m	122987
	<b>LEDGSM</b>		2 m Threaded 3-pin Pico pigtail QD	122986

\* For 9 m cable, add suffix **W/30** to the 2 m model number (example, **LEDRSW W/30**). QD models can be connected directly to P4 sensors; splitter cables available for powering two lights (see page 45).



## PresencePLUS® Linear Array Lights

- Maintenance-free LED illumination of large objects from far away
- Provides super high-intensity illumination of large areas
- Withstands washdown (rated IP68)



### Sealed LED Linear Array Lights

Voltage: **24V dc**

Length†	Model	Window	Description	Connection*	Data Sheet
12"	<b>LEDRLA290S-P</b>	Plastic	<b>Red</b>	0.15 m Threaded 4-pin Euro pigtail QD	127725
	<b>LEDRLA290S-G</b>	Glass			
	<b>LEDWLA290S-P</b>	Plastic	<b>White</b>		
	<b>LEDWLA290S-G</b>	Glass			
	<b>LEDBLA290S-P</b>	Plastic	<b>Blue</b>		
	<b>LEDBLA290S-G</b>	Glass			
	<b>LEDGLA290S-P</b>	Plastic	<b>Green</b>		
	<b>LEDGLA290S-G</b>	Glass			
24"	<b>LEDRLA580S-P</b>	Plastic	<b>Red</b>	0.15 m Threaded 4-pin Euro pigtail QD	127725
	<b>LEDRLA580S-G</b>	Glass			
	<b>LEDWLA580S-P</b>	Plastic	<b>White</b>		
	<b>LEDWLA580S-G</b>	Glass			
	<b>LEDBLA580S-P</b>	Plastic	<b>Blue</b>		
	<b>LEDBLA580S-G</b>	Glass			
	<b>LEDGLA580S-P</b>	Plastic	<b>Green</b>		
	<b>LEDGLA580S-G</b>	Glass			

\* Splitter cable available for powering two lights (see page 45).

† For replacement windows (see page 38).

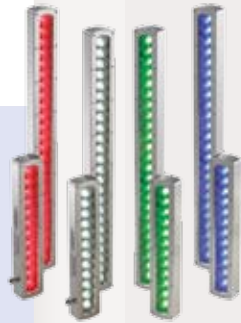

## PresencePLUS® Tubular Lights

- Provides easy, affordable, flicker-free illumination of large objects
- Uses waterproof housings (rated IP67) with integrated mounting brackets



### Sealed Fluorescent Tubular Lights

Voltage: **Varies**



Length	Model	Voltage	Ballast	Data Sheet		
8"	<b>HFFW8DC</b>	24V dc	Integral	115387		
8"	<b>HFFW8AC110</b>	110V ac				
8"	<b>HFFW8AC230</b>	230V ac				
12"	<b>HFFW12DC</b>	24V dc				
12"	<b>HFFW12AC</b>	120 to 277V ac				
14"	<b>HFFW14DC</b>	24V dc				
15"	<b>HFFW15AC110</b>	110V ac				
15"	<b>HFFW15AC230</b>	230V ac				
24"	<b>HFFW24AC</b>	120 to 277V ac				
36"	<b>HFFW36AC</b>	120 to 277V ac				
48"	<b>HFFW48AC</b>	120 to 277V ac				
8"	<b>HFFW8ACR</b>	120 to 277V ac			Remote	115387
12"	<b>HFFW12ACR</b>	120 to 277V ac				
15"	<b>HFFW15ACR</b>	120 to 277V ac				
24"	<b>HFFW24ACR</b>	120 to 277V ac				
36"	<b>HFFW36ACR</b>	120 to 277V ac				
48"	<b>HFFW48ACR</b>	120 to 277V ac				

Note: Replacement bulbs available, contact factory for information. All models have louvers and integral mounting flange; optional brackets are available for heavy-duty mounting (two brackets required for each light, see page 41).







## PresencePLUS® On-Axis Lights

- Provides more uniform illumination than a ring light
- Delivers collimated illumination in same optical path as camera
- Evenly illuminates on flat reflective material



### LED On-Axis Lights

Voltage: 24V dc

Size	Model	Description	Connection*	Data Sheet
100 x 100 mm	LEDRO100W	Red	2 m	126059
	LEDRO100M		0.6 m Threaded 3-pin Pico pigtail QD	
	LEDRO100W-D	Red, w/dust cover	2 m	
	LEDRO100M-D		0.6 m Threaded 3-pin Pico pigtail QD	
	LEDWO100W	White	2 m	
	LEDWO100M		0.6 m Threaded 3-pin Pico pigtail QD	
	LEDWO100W-D	White, w/dust cover	2 m	
	LEDWO100M-D		0.6 m Threaded 3-pin Pico pigtail QD	
	LEDBO100W	Blue	2 m	
	LEDBO100M		0.6 m Threaded 3-pin Pico pigtail QD	
	LEDBO100W-D	Blue, w/dust cover	2 m	
	LEDBO100M-D		0.6 m Threaded 3-pin Pico pigtail QD	
	LEDGO100W	Green	2 m	
	LEDGO100M		0.6 m Threaded 3-pin Pico pigtail QD	
	LEDGO100W-D	Green, w/dust cover	2 m	
	LEDGO100M-D		0.6 m Threaded 3-pin Pico pigtail QD	
LEDIO100W	Infrared	2 m		
LEDIO100M		0.6 m Threaded 3-pin Pico pigtail QD		



\* For 9 m cable, add suffix **W/30** to the 2 m model number (example, **LEDRO100W W/30**).  
QD models can be connected directly to P4 sensors.

### Specialty LED On-Axis Lights

Voltage: 12V dc

Size	Model	Description	Connection*	Data Sheet
25 mm dia.	LEDRO25N	Red	0.5 m with 9-pin D-sub connector	67437
	LEDWO25N	White		
	LEDBO25N	Blue		
50 mm dia.	LEDRO50N	Red	2 m with 9-pin D-sub connector	67438
	LEDRO50N-D	Red, w/dust cover		
	LEDWO50N	White		
	LEDBO50N	Blue		
75 mm dia.	LEDIO50N	Infrared	0.5 m with 9-pin D-sub connector	67439
	LEDRO75N	Red		
	LEDRO75N-H	Red, high output		
	LEDWO75N	White		
	LEDBO75N	Blue		



\* Specialty lights are not stocked and are non-returnable; they require an external power supply (see page 46).



## PresencePLUS® Highly Diffused Lights

- Minimizes glare and shadows
- Illuminates curved surfaces softly and evenly
- Minimizes texture

### Specialty LED Highly Diffused Lights

Voltage: 12V dc



Size	Model	Description	Connection*	Data Sheet
150 mm dia.	LEDRD150N	Red, dome	1.8 m with 9-pin D-sub connector	66955
25 mm dia.	LEDRS25N	Red	0.5 m with 9-pin D-sub connector	67441
75 mm dia.	LEDRS75N	Red		67442
	LEDGS75N	Green		



\* Specialty lights are not stocked and are non-returnable; they require an external power supply (see page 46).

## PresencePLUS® Low-Angle Ring Lights

- Highlights surface irregularities
- Highlights changes in elevation
- Illuminates from an angle nearly perpendicular to object

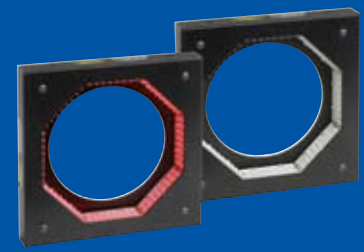

### LED Low-Angle Ring Lights

Voltage: **24V dc**

Size	Model	Description	Connection*	Data Sheet
150 mm dia.	<b>LEDRI150-3W</b>	<b>Red</b>	2 m	127582
	<b>LEDII150-3M</b>		2 m Threaded 3-pin Pico pigtail QD	
	<b>LEDII150-3W</b>	<b>Infrared</b>	2 m	
	<b>LEDII150-3M</b>		2 m Threaded 3-pin Pico pigtail QD	



\* For 9 m cable, add suffix **W/30** to the 2 m model number (example, **LEDRI150-3W W/30**). QD models can be connected directly to P4 sensors.

### Specialty LED Low-Angle Ring Lights

Voltage: **12V dc**

Size	Model	Description	Connection*	Data Sheet
100 mm dia.	<b>LEDRI100N</b>	<b>Red</b>	1.8 m with 9-pin D-sub connector	67432



\* Specialty lights are not stocked and are non-returnable; they require an external power supply (see page 46).

## PresencePLUS® Multi-Lights

- Provides multiple lighting angles and highly diffused lighting

### Specialty LED Multi-Lights

Voltage: **12V dc**

Size	Model	Description	Connection*	Data Sheet
50 mm dia.	<b>LEDRM50N</b>	<b>Red</b> low-angle & on-axis	1.8 m with 9-pin D-sub connector	67435
	<b>LEDRM50N-H</b>	<b>Red</b> low-angle & on-axis, high output		
75 mm dia.	<b>LEDRM75N</b>	<b>Red</b> low-angle & on-axis		67436
150 mm dia.	<b>LEDRC150N</b>	<b>Red</b> low-angle & on-axis multi-light		67443
200 mm dia.	<b>LEDRC200N</b>	<b>Red</b> low-angle & on-axis multi-light		67444



NOTE: Specialty lights are not stocked and are non-returnable; they require an external power supply (see page 46).



## Laser Emitters for Structured Illumination

- Provides high-contrast illumination
- Senses surface height differences
- Provides 3D inspection with a 2D camera

### QS18 Laser Emitters

Voltage: **10 to 30V dc**

Model	Description	Connection*	Data Sheet
<b>QS186LE212</b>	Extra Bright Horizontal Line (Class 2)	2 m	109415



\* For 9 m cable, add suffix **W/30** to the 2 m model number (example, **QS186LE212 W/30**).

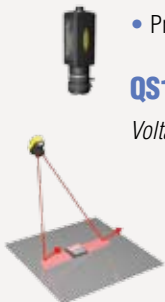



## PresencePLUS® Lighting Accessories

- Filters and diffusers for blocking light and improving lighting quality
- Window replacements for PresencePLUS Ring Lights, Area Lights, Backlights and Linear Array Lights

### Lighting Diffusers



Model	Description	Use With
<b>LEDRDW</b>	White Diffusing Window Kit	80 x 80 mm Ring Lights
<b>LEDRCDW</b>	Clear Diffusing Window Kit	80 x 80 mm Ring Lights
<b>LEDRDWS</b>	White Diffusing Window Kit	62 x 62 mm Ring Lights
<b>LEDRCDWS</b>	Clear Diffusing Window Kit	62 x 62 mm Ring Lights
<b>LEDADW</b>	White Diffusing Window Kit	80 x 80 mm Area Lights
<b>LEDADWS</b>	White Diffusing Window Kit	62 x 62 mm Area Lights

### Window Replacements



Model	Description	Use With
<b>LEDRCW</b>	Clear Plastic Window Replacement	80 x 80 mm Ring Lights
<b>LEDRCWS</b>		62 x 62 mm Ring Lights
<b>LEDAW</b>		80 x 80 mm Area Lights
<b>LEDAWS</b>		62 x 62 mm Area Lights
<b>LEDLA290SW-P</b>	Clear Glass Window Replacement	12" Sealed Linear Array Lights
<b>LEDLA580SW-P</b>		24" Sealed Linear Array Lights
<b>LEDLA290SW-G</b>		12" Sealed Linear Array Lights
<b>LEDLA580SW-G</b>		24" Sealed Linear Array Lights
<b>LEDBW</b>	White Window Replacement	70 x 70 mm Red Backlights
<b>LEDBIW</b>		70 x 70 mm Infrared Backlights
<b>LEDBWL</b>		85 x 220 mm Red Backlights
<b>LEDBIWL</b>		85 x 220 mm Infrared Backlights

### Filters

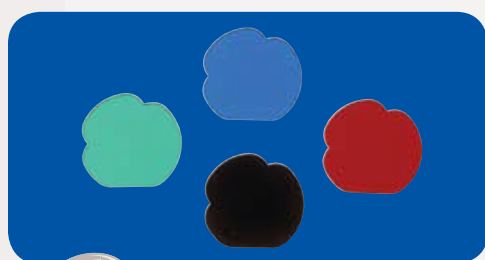

Choosing a Filter

Model	Color	Description	Data Sheet
<b>FLTI</b>	Infrared (≥ 760 nm)	High-pass filter blocks visible light and passes infrared light. Included with all Banner Infrared light sources.	69461
<b>FLTB</b>	Blue (400-525 nm)	Band-pass filter improves quality by helping to reduce ambient light; it passes blue and infrared light.	115635
<b>FLTG</b>	Green (400-575 nm)	Band-pass filter improves quality by helping to reduce ambient light; it passes green and infrared light.	115634
<b>FLTR</b>	Red (≥ 600 nm)	High-pass filter improves quality by helping to reduce ambient light; it passes red and infrared light.	69628
<b>LEDRRPFK</b>	—	Polarizing filter kit for 80 x 80 Ring Lights	108945
<b>LEDRRPFKS</b>	—	Polarizing filter kit for 62 x 62 Ring Lights	108945
<b>LEDAPFK</b>	—	Polarizing filter kit for 80 x 80 Area Lights and 70 x 70 Backlights	113657
<b>LEDAPFKS</b>	—	Polarizing filter kit for 62 x 62 Area Lights	113657
<b>LEDRPFK90</b>	—	Polarizing filter kit for Sealed Ring Lights	129871
<b>LEDFTK</b>	—	Kit with a variety of filters, diffusers and window replacements	—





## PresencePLUS® Lenses

- Wide choice of C-mount lenses for desired field of view at extended distances
- Standard, high-performance and megapixel lenses for extraordinary performance
- Models with focus and aperture locking



### PresencePLUS® Standard Lenses

Sensor Models: **AII** (except 1.3 megapixel models)

Model	Description	Format Size
<b>LCF04</b>	4 mm Lens	1/3"
<b>LCF08</b>	8 mm Lens	
<b>LCF12</b>	12 mm Lens with Focus Locking	
<b>LCF16</b>	16 mm Lens with Focus Locking	1"
<b>LCF25R</b>	25 mm Lens with Focus and Aperture	
<b>LCF25LR</b>	25 mm Lens with Focus and Aperture Locking, Metal Housing	2/3"
<b>LCF50L1R*</b>	50 mm Lens with Focus and Aperture Locking	
<b>LCF50L2R*</b>	50 mm Lens with Focus and Aperture Locking, Metal Housing	1"
<b>LCF75LR*</b>	75 mm Lens with Focus and Aperture Locking, Metal Housing	
<b>LEK</b>	C-mount Lens Extension Kit (0.5, 1.0, 5.0, 10, 20 and 40 mm)	—
<b>LEKS</b>	C-mount Lens Extension Kit (0.25, and 0.5 mm)	



### PresencePLUS® High-Performance Lenses

Sensor Models: **AII** (except 1.3 megapixel models)

Model	Description	Format Size
<b>LCF03LT</b>	3.5 mm Lens with Focus and Aperture Locking	1/2"
<b>LCF1040LT*</b>	10 - 40 mm Lens with Zoom, and Focus and Aperture Locking	
<b>LCF06LT</b>	6.5 mm Lens with Focus and Aperture Locking	2/3"
<b>LCF08LT</b>	8 mm Lens with Focus and Aperture Locking	
<b>LCF12LT</b>	12 mm Lens with Focus and Aperture Locking	
<b>LCF16LT</b>	16 mm Lens with Focus and Aperture Locking	
<b>LCF25LT</b>	25 mm Lens with Focus and Aperture Locking	
<b>LCF50LT</b>	50 mm Lens with Focus and Aperture Locking	
<b>LCF75LT</b>	75 mm Lens with Focus and Aperture Locking	—
<b>FLTUV</b>	UV Lens Filter, Clear Glass	
<b>LEK</b>	C-mount Lens Extension Kit (0.5, 1.0, 5.0, 10, 20 and 40 mm)	
<b>LEKS</b>	C-mount Lens Extension Kit (0.25 and 0.5 mm)	



### PresencePLUS® Megapixel Lenses

Sensor Models: **AII**

Model	Description	Format Size
<b>LCF08LMP</b>	8 mm Lens with Focus and Aperture Locking	2/3"
<b>LCF12LMP</b>	12 mm Lens with Focus and Aperture Locking	
<b>LCF16LMP</b>	16 mm Lens with Focus and Aperture Locking	
<b>LCF25LMP</b>	25 mm Lens with Focus and Aperture Locking	
<b>LCF35LMP</b>	35 mm Lens with Focus and Aperture Locking	
<b>LCF50LMP</b>	50 mm Lens with Focus and Aperture Locking	—
<b>LEK</b>	C-mount Lens Extension Kit (0.5, 1.0, 5.0, 10, 20 and 40 mm)	
<b>LEKS</b>	C-mount Lens Extension Kit (0.25 and 0.5 mm)	



\*Lens models will not fit in opening of Banner Ring Lights.



## PresencePLUS® Pro & P4 Brackets



### PresencePLUS® Pro

#### Camera



**SMBPPLU**  
Highly stable U-shaped long bracket



**SMBPPRA**  
Right-angle bracket with single-side mounting for difficult-to-access sites



**SMBPPU**  
U-shaped swivel bracket

### PresencePLUS® Pro

#### Controller



**SMBPPDH**  
DIN-rail flat mounting for easy viewing of LEDs



**SMBPPDE**  
DIN-rail edge mounting bracket to save linear track space

### Sealed PresencePLUS® Pro



**SMBPPSU**  
Swivel bracket for sealed Pro

### PresencePLUS® P4

#### Right-Angle



**SMBP4RAB**  
Heavy-duty bracket for right-angle P4



**SMBP4RAS**  
Swivel bracket for right-angle P4

# PresencePLUS® Lighting Brackets



## Area Lights

80 x 80



**SMBABM**  
Surface-mount bracket for mounting light from front



**SMBACM\***  
Column-mount bracket with locking pivot

62 x 62



**SMBP4ASM**  
For mounting one area light to the P4 housing



**SMBP42ASM**  
For mounting two area lights to P4 housing



**SMBP4ASM\***  
For mounting one area light to the P4 housing



**SMBP42ASM\*\***  
For mounting two area lights to P4 housing



**SMBVLA62X62S**  
Surface-mount bracket for mounting light from front



**SMBVLA62X62RA**  
For mounting an area light at a right angle

## Backlights

70 x 70



**SMBABM**  
Surface-mount bracket for mounting light from front



**SMBACM\***  
Column-mount bracket with locking pivot

## Tubular Fluorescent Lights



**SMBWFTLS**  
In-line bracket



**SMBWFTLR**  
Right-angle bracket

## Spot Light



**SMBP4ASM**  
For mounting one spot light to the P4 housing



**SMBP42ASM**  
For mounting two spot lights to P4 housing



**SMBPPLK**  
2" pivoting knuckle assembly for spot light

## On-Axis Lights



**SMBP40AL**  
For mounting on-axis light to P4 housing

\* Shown with optional SMBPPK6 mounting kit (see page 42).  
\*\* Requires one SMBACM bracket with each light.





## PresencePLUS® Mounting Systems & Enclosures

- Heavy-duty enclosure kits for protection of sensors and lights
- Adjustable mounting systems for flexible positioning of sensors and lights

### Adjustable Mounting Systems



SMBPPLK    SMBPPK6    SMBPPK3    SMBPPF1 & SMBPPFB

Model	Description	Used With
<b>SMBPPK3</b>	3" Column, Base, and Knuckle Kit	Pro, P4, Lights
<b>SMBPPK6</b>	6" Column, Base, and Knuckle Kit	
<b>SMBPPK</b>	Mounting Bracket Knuckle	
<b>SMBPPKE3</b>	3" Column	
<b>SMBPPKE6</b>	6" Column	
<b>SMBPPKB</b>	Mounting Bracket Base	
<b>SMBPPLK</b>	2" Mounting Knuckle Assembly	
<b>SMBPPF1</b>	Bogen Arm with Single Knob	
<b>SMBPPFB</b>	Bogen Arm Clamp	

### Enclosure Kits



Model P4RE67-G    Model PPE-G    Model PPE4-G

Model	Description	Data Sheet
<b>P4RE67-G</b>	Heavy-duty stainless-steel enclosure kit for <i>PresencePLUS P4</i> right-angle sensor and ring light - glass viewport; NEMA 6 rated	121996
<b>P4RE67-P</b>	Heavy-duty stainless-steel enclosure kit for <i>PresencePLUS P4</i> right-angle sensor and ring light - polycarbonate viewport; NEMA 6 rated	
<b>PPE-G</b>	Heavy-duty cold-rolled steel industrial protection kit for <i>PresencePLUS Pro</i> camera and lens - glass viewport; NEMA 1 rated	115342
<b>PPE-P</b>	Heavy-duty cold-rolled steel industrial protection kit for <i>PresencePLUS Pro</i> camera and lens - polycarbonate viewport; NEMA 1 rated	
<b>PPE-RG</b>	<i>PresencePLUS Pro</i> camera enclosure and industrial protection kit replacement glass viewport	None
<b>PPE-RP</b>	<i>PresencePLUS Pro</i> camera enclosure and industrial protection kit replacement polycarbonate plastic viewport	
<b>PPE4-G</b>	Heavy-duty stainless-steel enclosure kit for <i>PresencePLUS Pro</i> camera and ring light - glass viewport; NEMA 4 rated	111362
<b>PPE4-P</b>	Heavy-duty stainless-steel enclosure kit for <i>PresencePLUS Pro</i> camera and ring light - polycarbonate viewport; NEMA 4 rated	
<b>SMBPPES</b>	Mounting bracket, enclosure straight (PPE-P, PPE-G)	None
<b>SMBPPEA</b>	Mounting bracket, enclosure right angle (PPE-P, PPE-G)	
<b>SMBPPEF</b>	Mounting bracket, enclosure front (PPE-P, PPE-G)	



# Monitors & Indicator Lights

- Video monitors for easy viewing of inspections in real-time
- EZ-LIGHT™ indicators for clear visual indication of part status



## Monitors

Sensor Models: **Pro, P4**

Model	Description	Data Sheet
<b>PPM9</b>	9" Black and White NTSC Video Monitor	None

\*Monitors require a BNC cable for connection to a PresencePLUS Sensor (see page 44).



PPM9



Flat Panel Monitor

## EZ-LIGHT™ Indicators, Multi-Color, 7-Function

Model	Construction	Connection*	LED Function	Inputs	Data Sheet
<b>M18GRY2PQ</b>	18 mm mount Nickel-plated brass	4-pin Euro QD	Choose Red, Yellow or Green ON, flashing or alternating 	PNP	121902
<b>M18GRY2NQ</b>				NPN	
<b>T30GRY2PQ</b>	30 mm mount Thermoplastic polyester			PNP	
<b>T30GRY2NQ</b>				NPN	
<b>K50LGRY2PQ</b>	30 mm mount Thermoplastic polyester			PNP	
<b>K50LGRY2NQ</b>				NPN	
<b>K80LGRY2PQ</b>	Flat or DIN mount Thermoplastic polyester			PNP	
<b>K80LGRY2NQ</b>				NPN	

\***K80L Models:** QD models are listed. For terminal wiring option, omit **Q** from model number (example, **K80LGRY2P**). A model with a QD requires a mating cable (see page 45).

**Other Models:** QD models are listed. For 2 m cable, omit suffix **Q** from model number (example, **M18GRY2P**). A model with a QD requires a mating cable (see page 45).



M18



T30



K50L



K80L



## PresencePLUS® Cables & Cordsets

- Cables for sensors, cameras, video, serial and Ethernet connections
- Sealed cables for powering sealed lights and cameras
- High-flex cables for applications requiring articulated or reciprocated motion
- Splitter cable for powering two lights from one P4 sensor

### Pro Camera-to-Controller Cordsets

#### 12-Pin QD to DB15

Sensor Models: **Pro**



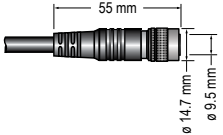
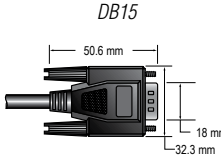
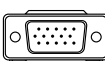
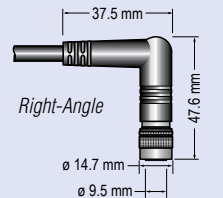
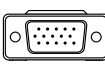

End View	Model	Description	Length	Dimensions	
Male QD 	PPC06	Male Straight/ Male DB15	2 m	<i>Straight</i> 	
	PPC23		7 m		
	PPC32		10 m		
Male DB15 	PPC06HF	Male Straight (High-Flex)/ Male DB15	2 m	<i>Right-Angle</i> 	
	PPC23HF		7 m		
	PPC32HF		10 m		
Male DB15 	PPC06RA	Male Right-Angle/ Male DB15	2 m		
	PPC10RA		3 m		
	PPC23RA		7 m		
	PPC32RA	10 m			
	PPC06RAHF	Male Right-Angle (High-Flex)/ Male DB15	2 m		
	PPC23RAHF		7 m		
PPC32RAHF	10 m				

#### 12-Pin QD to DB15

Sensor Models: **Sealed Pro**

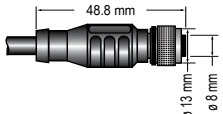
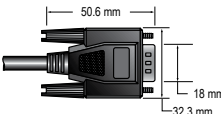

End View	Model	Description	Length	Dimensions	
Female QD 	PPC13S	Female Straight/ Male DB15	4 m	<i>Straight</i> 	
Male DB15 	PPC23S		7 m		
	PPC32S		10 m		

### P4 Cables & Cordsets

#### 12-Pin QD

Sensor Models: **P4, PPSIM**  
with terminal strip to P4



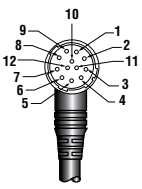
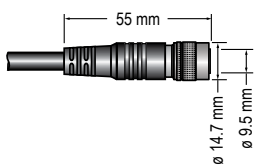

End View	Model	Description	Length	Dimensions	
Female QD  1 = Yellow 2 = Gray 3 = Orange 4 = Pink 5 = Black* 6 = Red* 7 = White* 8 = Light Blue* 9 = Purple 10 = Green 11 = Blue 12 = Brown Shield = Bare Metal	P4C06	Female Straight	2 m	<i>Straight</i> 	
	P4C23		7 m		
	P4C32		10 m		
	P4C50		16 m		
	P4C75		23 m		

#### 12-Pin QD to DB15

Sensor Models: **P4 to PPSIM**  
with DB15 connector

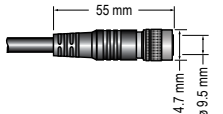
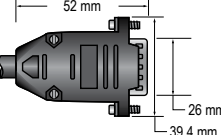

End View	Model	Description	Length	Dimensions	
Female QD 	P4C06SIM	Female Straight/ Male DB15	2 m	<i>Straight</i> 	
Male DB15 	P4C23SIM		7 m		
	P4C32SIM		10 m		

### Video Cordsets

#### BNC Coaxial Cordsets

Sensor Models: **Pro, P4**

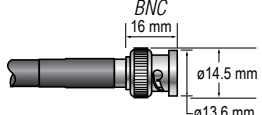

End View	Model	Description	Length	Dimensions	
Male 	BNC06	Video Coaxial with BNC	2 m	<i>BNC</i> 	
	BNC15		5 m		
	BNC30		9 m		





## Communications Cordsets

### RJ45 Ethernet

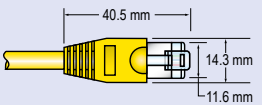

Sensor Models: **Pro, P4**

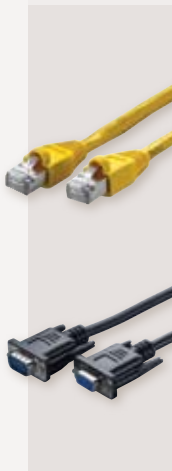
End View	Model	Description	Length	Dimensions
	<b>STP07</b>	Cat5e Shielded	2.1 m	
	<b>STPX07</b>	Cat5e Crossover Shielded		
	<b>STP25</b>	Cat5e Shielded	7.3 m	
	<b>STPX25</b>	Cat5e Crossover Shielded		
	<b>STPX75</b>	Cat5e Shielded		

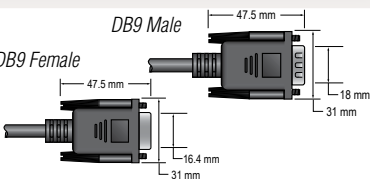

### DB9 Serial

Sensor Models: **Pro**

End View	Model	Description	Length	Dimensions
	<b>DB9P06</b>	Male DB9/ Female DB9	2 m	
	<b>DB9P15</b>		5 m	
	<b>DB9P30</b>		9 m	

## Light Cables & Cordsets

### 3-Pin Pico QD

Light Models: **Sealed Ring Lights**

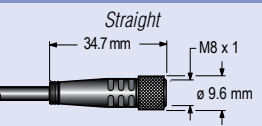
End View	Model	Description	Length	Dimensions
	<b>PKG3M-4</b>	Female Straight	4 m	
	<b>PKG3M-7</b>		7 m	
	<b>PKG3M-10</b>		10 m	

### 4-Pin Euro QD

Light Models: **Sealed Linear Array Lights, EZ-LIGHT**

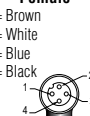
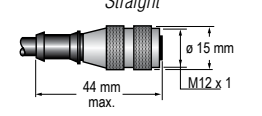
End View	Model	Description	Length	Dimensions
	<b>MQDC-406</b>	Female Straight	2 m	
	<b>MQDC-415</b>		5 m	
	<b>MQDC-430</b>		9 m	

## Splitter Cables

### 3-Pin Pico Splitters

Light Models: **Ring Lights, Area Lights, Spot Lights and Backlights**

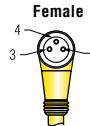
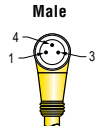
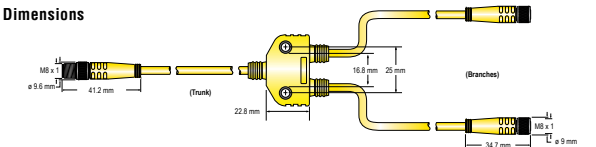
End View	Model	Branches	Trunks
 	<b>CSB-M831M831</b>	3-Pin Pico QD 2 x 0.2 m Female	0.2 m Male
			

### 4-Pin Euro Splitters

Light Models: **Sealed Linear Array Lights, EZ-LIGHT**

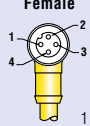
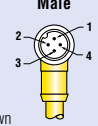
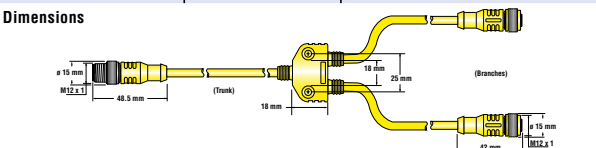
End View	Model	Branches	Trunks
 	<b>CSB-M1241M1241</b> <b>CSB-UNT425M1241</b>	4-Pin Euro QD 2 x 0.3 m Female	0.3 m Male 8 m unterminated
			



## PresencePLUS® Interface Modules

- Sensor interface modules provide a dc powered interface for PresencePLUS P4 vision sensors
- Lighting interface modules allows strobe operation of Banner's lighting with any vision sensor or vision system
- Strobe control module provides control of specialty strobed LED lights
- Power supplies provide power to continuous LED lights or PresencePLUS vision sensors



### PresencePLUS® Sensor Interface Modules

Sensor Models: **P4**

Model	Outputs	Connections	Data Sheet
<b>PPSIM-NT</b>	Current Sinking (NPN)	Two 13-pin Terminals	126330
<b>PPSIM-NC</b>		One 13-pin Terminals One DB-15 Connector	
<b>PPSIM-PT</b>	Current Sourcing (PNP)	Two 13-pin Terminals	126330
<b>PPSIM-PC</b>		One 13-pin Terminals One DB-15 Connector	



### Light Interface Modules

Used with Banner  
Vision Lights

Model	Supply Voltage	Strobe Output	Data Sheet
<b>PPLIM</b>	24V dc	5V @ 10 mA max.	128190



### Strobe Control Module

Used with specialty lights  
ending in N or N-S

Model	Input	Trigger Input	Output	Output Pulse Range	Data Sheet
<b>SCM*</b>	24V dc $\pm 5\%$ 2 A max.	5V @ 10 mA max.	2-channels 24V dc $\pm 5\%$ 9A nominal per channel @ 60 Hz	5 to 1,300 microseconds	67448



### Continuous Power Supplies

PSA.. & PSC..



PSDINA-24

Model	Input	Input Cord	Outputs	Output Cable	Used With	Data Sheet
<b>PSA-12</b>	100-250V ac 50/60 Hz	North America (NEMA 5-15)	12V dc $\pm 5\%$ with voltage regulation of $\pm 1\%$ 3.5 A max.	1.8 m Terminated with 9-pin D-sub connector (female pins)	Continuous LED Lights	67445
<b>PSA-12E</b>		Cont. Europe (Schuko CEE 7)				
<b>PSA-24</b>	100-250V ac 50/60 Hz	North America (NEMA 5-15)	24V dc $\pm 5\%$ with voltage regulation of $\pm 1\%$ 2.2 A max.	1.8 m Terminated with 9-pin D-sub connector (female pins)	Continuous LED Lights	67447
<b>PSA-24E</b>		Cont. Europe (Schuko CEE 7)				
<b>PSC-24*</b>	115-250V ac 50/60 Hz (Auto Select)	North America (NEMA 5-15)	24V dc $\pm 5\%$ with voltage regulation of $\pm 1\%$ 2.2 A max.	1.8 m 2-wire Unterminated	SCM Strobe Control Module	67446
<b>PSC-24E*</b>		Cont. Europe (Schuko CEE 7)				
<b>PSDINA-24</b> (DIN-rail mountable)	115-230V ac (Auto Select)	—	24V dc @ 2.5 A max.	—	P4, Pro & Lights	—



\* These products are not stocked and are non-returnable.

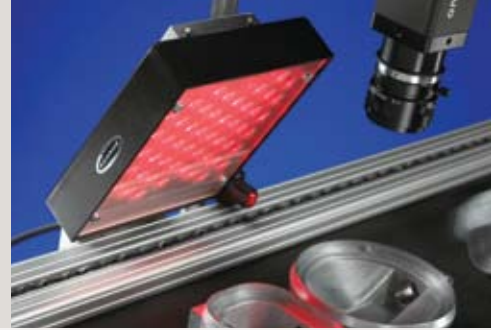

## Test Power Supply

Sensor Models: **P4**

Model	Input	Input	Trigger Option	Data Sheet
<b>P4D1</b>	100-240V ac	North America (AC plug)	<ul style="list-style-type: none"> <li>• 24V dc NPN Sensor</li> <li>• Continuous pulse</li> <li>• Single pulse</li> </ul>	—

Note: 1 amp power supply used to power *P4* sensor and lighting for proving an application without integration into a control panel.



## Lighting Variable Power Supplies\*

Model	Input	Input Cord	Outputs	Output Cable	Used With	Data Sheet
<b>PS2V-12</b>	100-140V ac 60 Hz	North America (NEMA 5-15)	2-channels 6-12V dc	1.8 m Terminated with 9-pin D-sub connector (female pins)	Continuous LED Lights	67449
<b>PS2V-12E</b>	200-250V ac 50 Hz	Cont. Europe (Schuko CEE 7)	2 A max. per channel			

**MORE  
INFO  
ONLINE**



## Lighting Power Supply Extension Cables\*

Model	Length	Input Cord	Used With
<b>DB906</b>	1.8 m	Cable powers one continuous light (one end male pins and one end female; both ends terminated with 9-pin D-sub connector)	Continuous LED Lights
<b>DB910</b>	3.0 m		
<b>DB9Y</b>	1.8 m	Cable powers two continuous lights with one supply (9 m trunk with male connector and 9 m branches with female connector; ends terminated with 9-pin D-sub connector)	Continuous LED Lights
<b>DB906S</b>	1.8 m	Cable powers one strobed light (one end male pins and one end female; both ends terminated with 9-pin D-sub connector)	Strobed LED Lights
<b>DB910S</b>	3.0 m		
<b>DB9YS</b>	1.8 m	Cable powers one strobed light (9 m trunk with male connector and 9 m branches with female connector; ends terminated with 9-pin D-sub connector)	Strobed LED Lights

\* These products are not stocked and are non-returnable.

## Additional Literature

Description	Used With	Data Sheet
<i>PresencePLUS</i> Software on CD-ROM—Available for Download Online	<i>Pro</i> , <i>P4</i>	72806
<i>Pro</i> Sensors Manual	<i>Pro</i>	68367
<i>Pro</i> COLOR Sensors Manual*	<i>Pro</i> COLOR	77574
<i>Pro</i> & <i>Pro</i> COLOR Quick Start Guide	<i>Pro</i>	68369
<i>P4</i> OMNI & OMNI 1.3 Sensors Manual	<i>P4</i> OMNI, <i>P4</i> OMNI 1.3	125808
<i>P4</i> COLOR Sensor Manual*	<i>P4</i> COLOR	77575
<i>P4</i> GEO and GEO 1.3 Sensors Manual	<i>P4</i> GEO, <i>P4</i> GEO 1.3	121555
<i>P4</i> AREA & AREA 1.3 Sensors Manual	<i>P4</i> AREA, <i>P4</i> AREA 1.3	125439
<i>P4</i> EDGE and EDGE 1.3 Sensors Manual	<i>P4</i> EDGE, <i>P4</i> EDGE 1.3	120413
<i>P4</i> BCR & BCR 1.3	<i>P4</i> BCR, <i>P4</i> BCR 1.3	122800
<i>P4</i> Quickstart Guide	<i>P4</i>	118000

\* Available Q2 2007

**MORE  
INFO  
ONLINE**





## Product Information

Machine Safety Products

**Measurement & Inspection Sensors**

**PresencePLUS® P4 COLOR Series**

One point multi-function color vision sensor.



- Uses the Color Map tool to inspect for specific colors
- Detects all P4 (P40) Gray Scale items: Machine Feed and Eject, Stop, Object, With, Run, High Torq, Stop, and Pressure
- Features models with optional Bar Code Reader
- Capable of inspecting using a 752 x 480 pixel color CMOS imager
- Offers high-performance vision inspection in a self-contained housing
- Uses one or more sensing heads for expanded application flexibility and unlimited sensor visibility
- Includes remote TEACH, configurable I/Os, but online and communications standard to all PresencePLUS sensors
- Offered in single or split in-line housing styles

**Media Learning**

- P4000-01-001-001-001
- P4000-01-001-001-001

Banner Engineering, Corp. Banner Worldwide - Microsoft Internet Explorer

File Edit View Favorites Tools Help

Address http://www.bannerengineering.com/

**BANNER ENGINEERING CORP.**

The Company Products What's New Applications Literature/Resources

Products Trade Shows Literature In the News

**BANNER ENGINEERING CORP.**

Banner offers you the most complete and integrated line of sensing and machine safety products. Whatever industry you're in, or whatever product you manufacture, Banner has the right sensors to automate your plants and improve your overall efficiency, quality and safety.

- ▶ Photoelectric Sensors
- ▶ Measurement and Inspection Sensors
- ▶ Machine Safety Products
- ▶ Vision Sensors

Add to Favorites...

**BANNER ENGINEERING .COM**

iSelect™ photoelectrics



http://www.bannerengineering.com/what\_new/

## Literature & Resources

**PresencePLUS® Pro Series - Literature**

**Product Instruction Manual**

- PresencePLUS Pro Installation Manual
- PresencePLUS Pro Operator's Manual
- PresencePLUS Pro Substrate Rules
- Serial Data Interface (P4000-01-001-001-001)

**Product Data Sheet**

- PresencePLUS Pro Substrate Rules
- Serial Data Interface (P4000-01-001-001-001)

**Job Aid**

- Changing the IP Address
- Using Color Filter

**Product Brochure**

- PresencePLUS Pro Substrate Rules
- PresencePLUS Pro Vision Sensor Brochure

**Media Learning**

- P4000-01-001-001-001

**Applications & Tutorials**

**Lighting: Effect on a Part**



Lighting can affect the way a part is inspected. The correct surface and the correct position of the target object are critical.

Checklist for lighting:

- Use a narrow beam
- Use a narrow beam

**iknow**

**BANNER®**  
more sensors, more solutions

1.888.3.SENSOR (1.888.373.6767)

Banner Engineering Corp., 9714 Tenth Avenue North, Minneapolis, MN 55441 U.S.A.  
Phone 763.544.3164 Fax 763.544.3213 bannerengineering.com email: sensors@bannerengineering.com  
PRINTED IN U.S.A. Copyright, 2007 Banner Engineering Corp.