

193987GA Encapsulated Temperature Sensor

The 193987GA Encapsulated Temperature Sensor is used with the T7075 or T775 family of solid state remote temperature controllers.

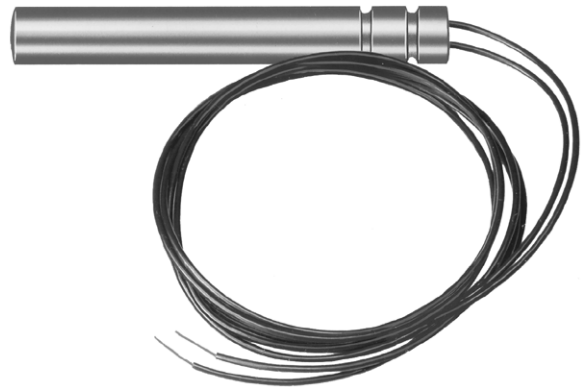

-
- No settings or calibration required.
 - Platinum positive temperature coefficient (PTC) sensing element.
 - High accuracy temperature sensing $\pm 1^{\circ}$ F [0.6° C] over a wide range of temperatures (-40° F [-40° C] to $+257^{\circ}$ F [125° C]).
 - Can be located up to 1000 ft [304m] from the controller.
 - Provides temperature sensing capability suitable for mounting in an immersion well.
 - Can be strap-mounted to a pipe.

CONTENTS

<i>Specifications</i>	2
<i>Ordering Information</i>	2
<i>Installation</i>	3
<i>Operation and Checkout</i>	5

Specifications

IMPORTANT: *The specifications given in this publication do not include normal manufacturing tolerances. Therefore, an individual unit may not exactly match the listed specifications. Also, this product is tested and calibrated under closely controlled conditions and some minor differences in performance can be expected if those conditions are changed.*

MODEL: 193987GA Encapsulated Temperature Sensor.
 ELECTRICAL RATING: 30 Vac maximum.
 AMBIENT TEMPERATURE RANGE: Operating and Shipping: -40° F to +257° F [-40° C to +125° C].
 SENSING ACCURACY: ±1° F [0.5° C].
 HUMIDITY: 90% relative humidity (RH) at 90° F [32° C] noncondensing environment.
 TEMPERATURE SENSOR RESISTANCE:

Temperature [°C]	-10°	0°	+10°	+20°	+30°	+40°
Temperature (°F)	14°	32°	50°	68°	86°	104°
Resistance in ohms	3,178	3,266	3,353	3,440	3,527	3,713

DIMENSIONS: See Fig. 1.

Fig. 1—Approximate dimensions of 193987GA Encapsulated Temperature Sensor in in. [mm].

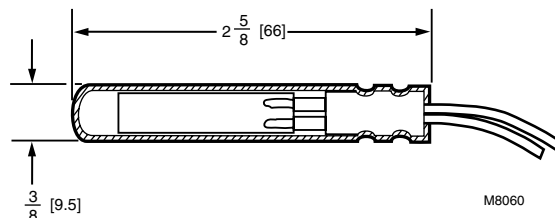

LEAD LENGTH: 1000 ft [304m] maximum.
 MOUNTING: 3 in. [76 mm] copper insertion bulb, 3/8 in. [9.5 mm] diameter; immersion wells available separately.
 OPTIONAL ACCESSORIES:
 T7047C1090 Sensor Case.
 105900 Pipe Strap: Fits up to 3/4 in. outside diameter pipe.
 121371A Immersion Well: 1/2 in. NPT copper.
 121371E Immersion Well: 1/2 in. NPT stainless steel.
 107408 Heat Conductive Compound: 4 ounce can.

Ordering Information

When purchasing replacement and modernization products from your wholesaler or distributor, refer to the price sheets for complete ordering number, or specify—

1. Order number.
2. Accessories, if desired.
3. Order additional system components and system accessories separately.

If you have additional questions, need further information, or would like to comment on our products or services, please write or phone:

1. Your local Home and Building Control Sales Office (please check the white pages of your phone directory).
2. Home and Building Control Customer Satisfaction
 Honeywell, Inc., 1885 Douglas Drive North
 Minneapolis, Minnesota 55422-4386 (612) 951-1000

In Canada—Honeywell Limited/Honeywell Limitee, 740 Ellesmere Road, Scarborough, Ontario M1P2V9. International Sales and Service Offices in all principal cities of the world. Manufacturing in Australia, Canada, Finland, France, Germany, Japan, Mexico, Netherlands, Spain, Taiwan, United Kingdom, U.S.A.

Installation

WHEN INSTALLING THIS PRODUCT...

1. Read these instructions carefully. Failure to follow them could damage the product or cause a hazardous condition.
2. Check the ratings given in the instructions and on the product to make sure the product is suitable for your application.
3. Installer must be a trained, experienced serviced technician.
4. After installation is complete, check out product operation as provided in these instructions.



CAUTION

Disconnect power supply before making wiring connections to prevent electrical shock or equipment damage.

SENSOR LOCATION

The 193987GA Sensor can be located up to 1000 feet [304 meters] from the T775/T7075 using standard AWG 18/2 unshielded wire. It can be located on pipes, in immersion wells, in wall-mounted cases or on a bulb holder.

SENSOR MOUNTING

The sensor can be mounted on a wall or panel for sensing space temperatures (see Fig. 2), strapped to a pipe (see Fig. 3), or inserted in a well (see Fig. 4) for hot/cold water sensing, or taped to a standard cap or bulb holder for duct air sensing (see Fig. 5).

NOTE: Use heat conductive compound in immersion wells.
See Optional Accessories.

Fig. 2—Sensor mounted on wall.

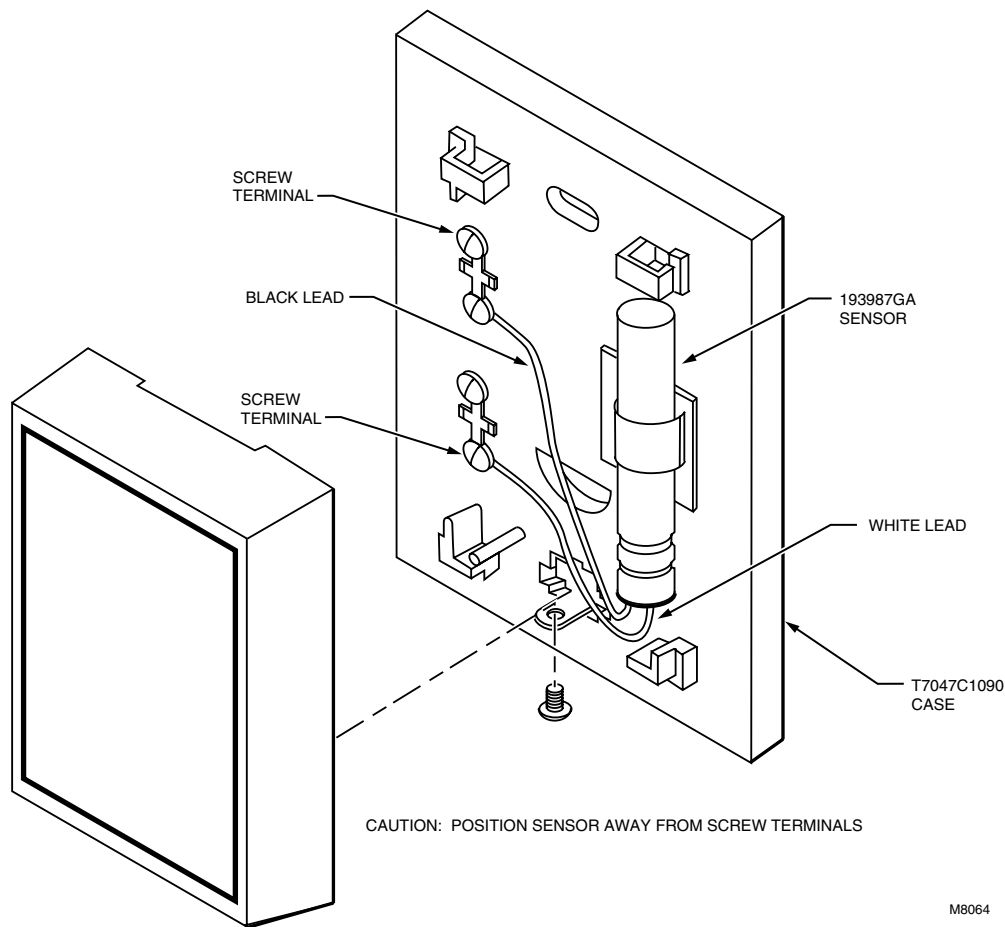

Fig. 3—Sensor strapped to hot/cold water pipe.

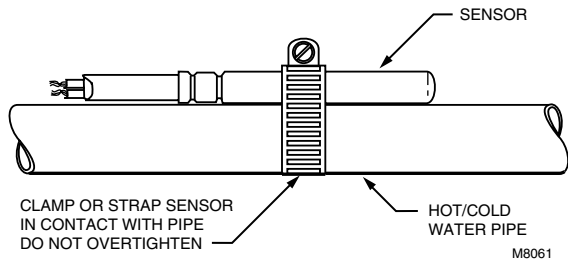

Fig. 4—Sensor inserted in immersion well.

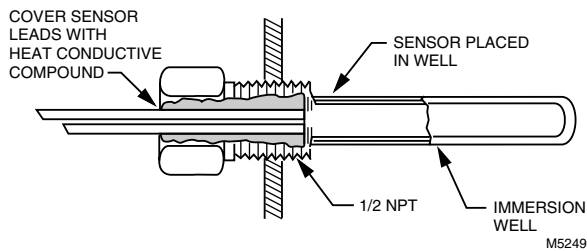
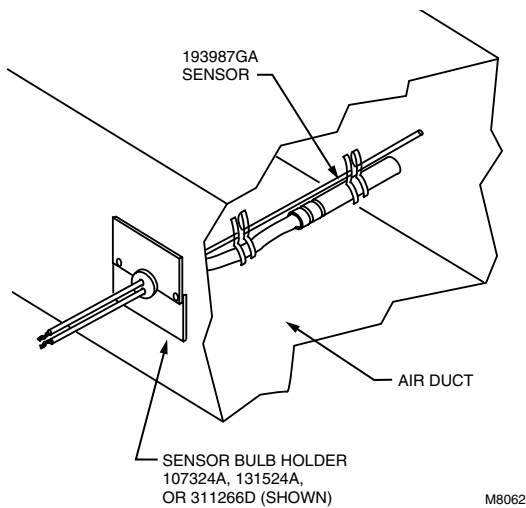

Fig. 5—Sensor mounted in air duct.



CAUTION

When mounting the sensor, position it so that condensation cannot run down the lead wire into the sensor capsule. See Fig. 2.

MOUNTING SENSOR IN T7047C CASE

1. Run wires from T775/T7075 through wall.
2. Mount case to wall with screws provided.
3. Connect wires from the T775/T7075 to two T terminals on the T7047C1090 case.

4. Cut and strip 193987GA sensor leads to 3/4 in. length and connect to screws at T terminals in case.

5. Position sensor as in Fig. 2, assemble cover and tighten cover screws.

CAUTION

Make sure that metal tube of sensor does not short against T terminals in wall-mounted case.

WIRING

1. Disconnect power supply before making wiring connections to prevent electrical shock or equipment damage. All wiring must agree with local codes, ordinances and regulations. Wire the 193987GA to the T775/T7075 using the procedures and diagrams outlined with the controller. Keep wiring runs as short as practical, and less than 1000 feet [304 meters]. A general wiring hookup is shown in Fig. 6. For specific limitations and wiring diagrams, refer to the instructions provided with the controller used with this sensor.

Fig. 6—General wiring hookup for the 193987GA Sensor and T775/T7075 Controller.

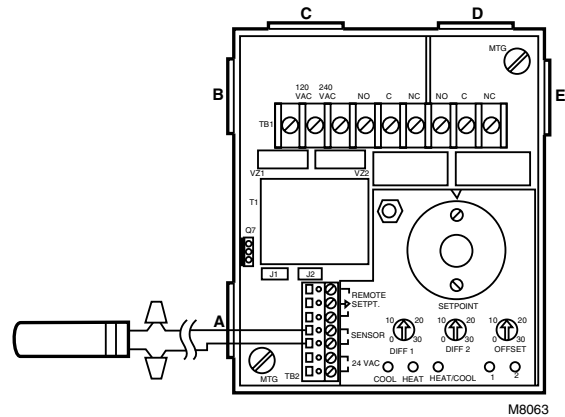

IMPORTANT: Erratic temperature readings from the 193987GA Sensor can be caused by poor wiring practices that must be avoided to assure proper operation:

- a. Do not route temperature sensor wiring with building power wiring.
- b. Do not locate temperature sensor wiring next to control contactors.
- c. Do not locate temperature sensor wiring near electric motors.
- d. Do not locate temperature sensor wiring near welding equipment.

Use shielded cable if any of the above conditions cannot be avoided.

Operation and Checkout

The 193987GA Sensor is a high accuracy solid state sensor for use in applications requiring a broad temperature sensing range. Unlike thermistors, the 193987GA has a positive temperature coefficient (PTC); resistance increases as the temperature increases. As shown in Fig. 7, the resistance curve increases by 4.8 ohms per degree F temperature rise [8.6 ohms per degree C].

Resistance in the sensor wiring positively offsets the temperature sensed by 1 degree F every 4.8 ohms [1 degree C every 8.6 ohms] of resistance. Use short wire lengths, or larger gauge wire when longer lengths are needed.

Fig. 7—Resistance vs. temperature performance characteristics.

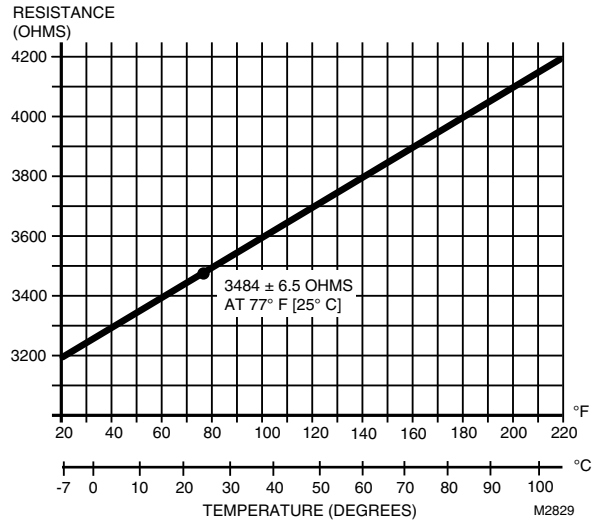

By using this Honeywell literature, you agree that Honeywell will have no liability for any damages arising out of your use or modification to, the literature. You will defend and indemnify Honeywell, its affiliates and subsidiaries, from and against any liability, cost, or damages, including attorneys' fees, arising out of, or resulting from, any modification to the literature by you.

Honeywell

Home and Building Control

Honeywell Inc.
1985 Douglas Drive North
Golden Valley, MN 55422

Home and Building Control

Honeywell Limited—Honeywell Limitée
740 Ellesmere Road
Scarborough, Ontario
M1P 2V9

Helping You Control Your World