

# V4295A,S; V8295A,S Solenoid Gas Valves

## INSTALLATION INSTRUCTIONS



## APPLICATION

The electrically operated V4295A, S and V8295A, S Solenoid Gas Valves control the flow of natural and LP (liquefied petroleum) gases.

These valves are used on atmospheric boilers, commercial water heaters, roof-top make-up air burners, power burners and boilers.

## FEATURES

- V4295A,S are used with 120 Vac controllers; V8295A,S are used with 24 Vac controllers.
- Models available in Normally Closed and Normally Open configurations.
- Normally Closed models, for safety shut-off applications, consist of a direct on/off operator for opening and closing of the valve.
- Normally Open models, for vent (double block and bleed) valve applications, consist of a direct electric on/off operator for closing and opening of the valve.
- Models are suitable for the control of gaseous fluids in gas consuming appliances according to international standards.
- Models have 1/4 inch NPT inlet and outlet pressure taps.
- Models have inlet screen to protect the valve from the entry of dirt.

## SPECIFICATIONS

### Models

V4295A Normally Closed (N.C.) Safety shut-off Valve, 120V  
 V4295S Normally Open (N.O.) Vent Valve, 120V  
 V8295A Normally Closed (N.C.) Safety shut-off Valve, 24V  
 V8295S Normally Open (N.O.) Vent Valve, 24V

### Type of gas

Air, Natural, Manufactured, Mixed and LP gas.

### Valve capacities

Refer to Figures 1 and 2

### Valve pattern

Straight through, non-offset

### Body Material

Die cast aluminum

### Electrical terminations

Screw terminal connections

### Valve opening time

Less than 1 second



**Valve closing time**  
Less than 1 second

**Maximum operating pressure**  
3/8 in. through 3 in. pipe sizes: 2 psi  
3/8 in. through 2 in. pipe sizes: 5 psi

**Current draw**

Normally Closed (N.C.) Pipe size (inch)	V4295A		V8295A
	120 Vac		24 Vac
	2 psi	5 psi	2 psi
3/8 and 1/2	0.160 A	0.160 A	0.80 A
3/4 and 1	0.160 A	0.200 A	0.80 A
1-1/4	0.340 A	0.550 A	1.60 A
1-1/2	0.300 A	0.550 A	1.70 A
2	0.525 A	0.540 A	2.80 A
2-1/2	0.575 A	n/a	n/a
3	0.675 A	n/a	n/a

Normally Open (N.O.) Pipe size (inch)	V4295A	V8295A
	120 Vac	24 Vac
	2 psi	
3/4 and 1	0.160 A	0.80 A
1-1/4	0.340 A	2.40 A

**Table 1. Models Available.**

Model	Voltage/Frequency	Maximum Pressure		Pipe size (inch)	Thread type
		psi	mbar		
V4295A (N.C.)	110/120 Vac, 50/60 Hz	2.0	140	3/8, 1/2, 3/4, 1, 1-1/4, 1-1/2, 2, 2-1/2, 3	NPT
V4295A (N.C.)	110/120 Vac, 50/60 Hz	5.0	350	3/8, 1/2, 3/4, 1, 1-1/4, 1-1/2, 2	NPT
V4295S (N.O.)	110/120 Vac, 50/60 Hz	2.0	140	3/4, 1, 1-1/4	NPT
V8295A (N.C.)	24 Vac, 50/60 Hz	2.0	140	3/8, 1/2, 3/4, 1, 1-1/4, 1-1/2, 2	NPT
V8295S (N.O.)	24 Vac, 50/60 Hz	2.0	140	3/4, 1, 1-1/4	NPT

**Table 2. Capacity in CFH at Pressure Drop of 1-Inch Water Column sp. gr. = 0.64 for V4295A, V8295A (N.C.).**

	3/8 in.	1/2 in.	3/4 in.	1 in.	1-1/4 in.	1-1/2 in.	2 in.	2-1/2 in.*	3 in.*
2 psi	230	250	645	790	1,450	2,190	3,465	5,070	6,100
5 psi	210	290	610	825	1,950	2,270	3,740	n.a.	n.a.

\* V4295A only

**Table 3. Capacity in CFH at Pressure Drop of 1-Inch Water Column sp. gr. = 0.64 for V4295S, V8295S (N.O.).**

3/4 in.	1 in.	1-1/4 in.
350	420	1,100

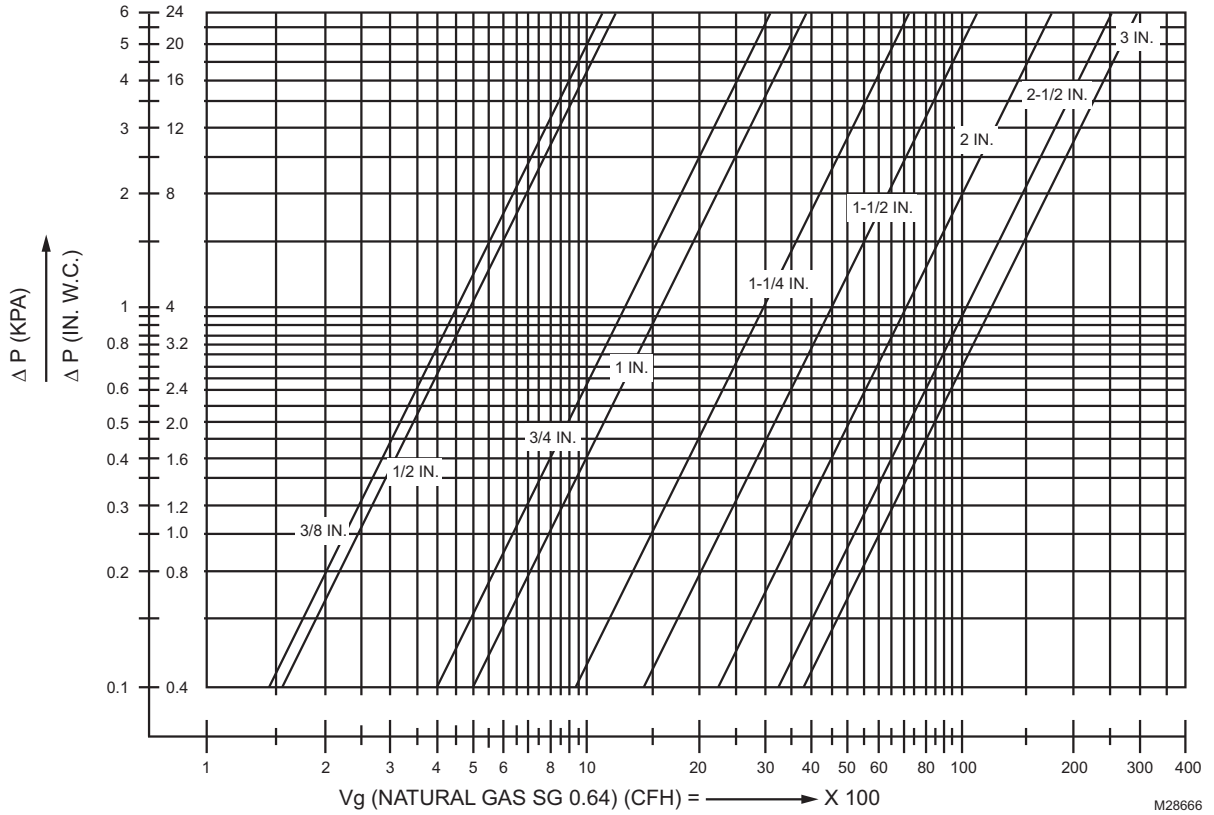

Fig. 1. Capacity curves for V4295A and V8295A, 2 psi versions.

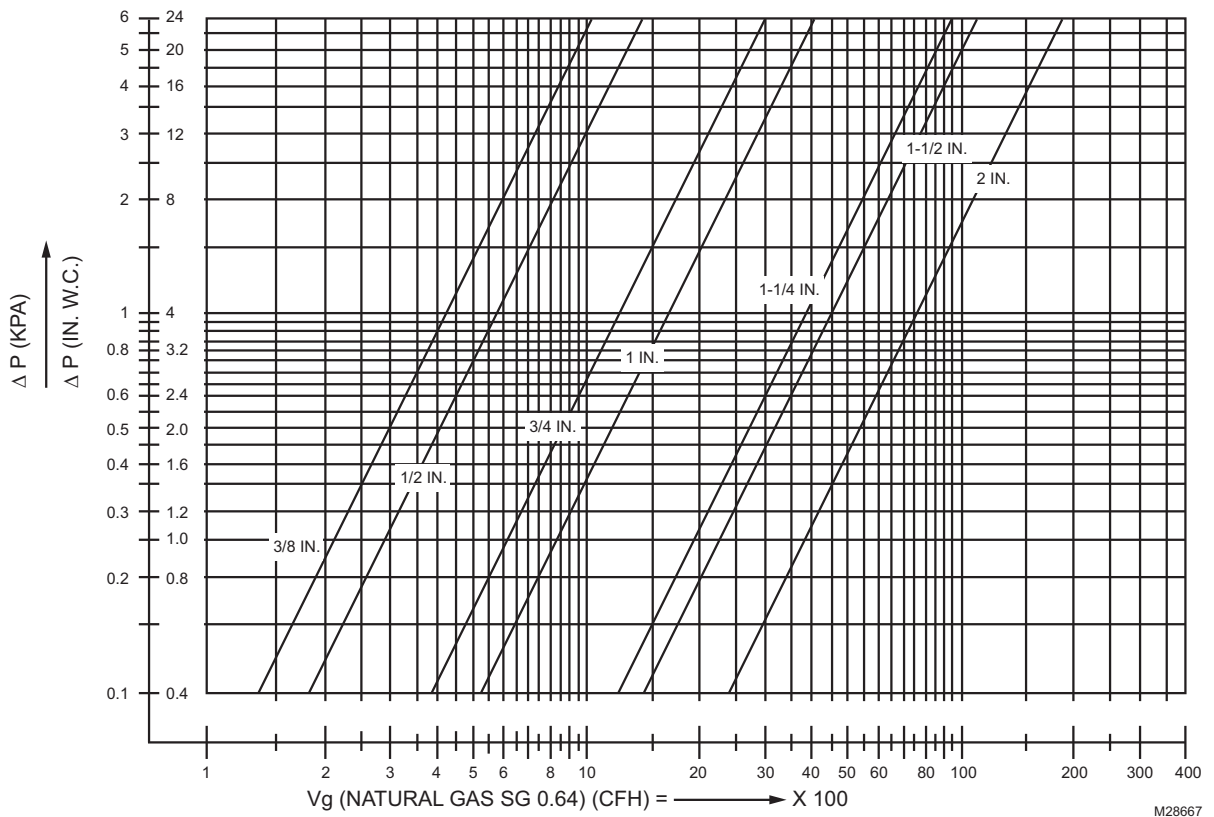

Fig. 2. Capacity curves for V4295A, 5 psi versions.

**Ambient temperature rating**

-40°F to 145°F (-40°C to 63°C)

**Maximum fluid temperature rating**

-40°F to 145°F (-40°C to 63°C)

**Mounting position**

Vertical to 90 degrees from vertical, refer to Fig. 5.

**Dimensions and weight**

Refer to Figures 3 and 4.

**Approvals**

Underwriters Laboratories, Inc., File Number MH 18476,  
Guide number YLOZ

AGA and CGA, File Number C2030014

Complies with standard ANSI Z21.21-CGA6.5

Automatic Valves for gas appliances and automatic safety  
shut-off gas valves (revised edition of the former ANSI  
Z21.21, CAN/CGA-6.5-M89, CAN/CGA-3.9-M87)

**Factory Mutual:**

V4/8295A: 2 psi rated, 3/8 in. to 3/4 in.

V4/8295A: 5 psi rated, 3/8 in. to 2 in.

V4/8295S: All

CSD-1 Acceptable.

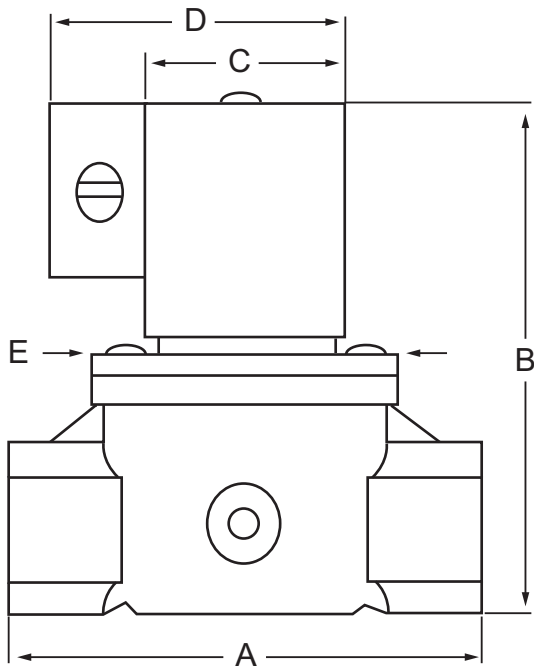

M28661

**Fig. 3. Dimensions (normally closed).**

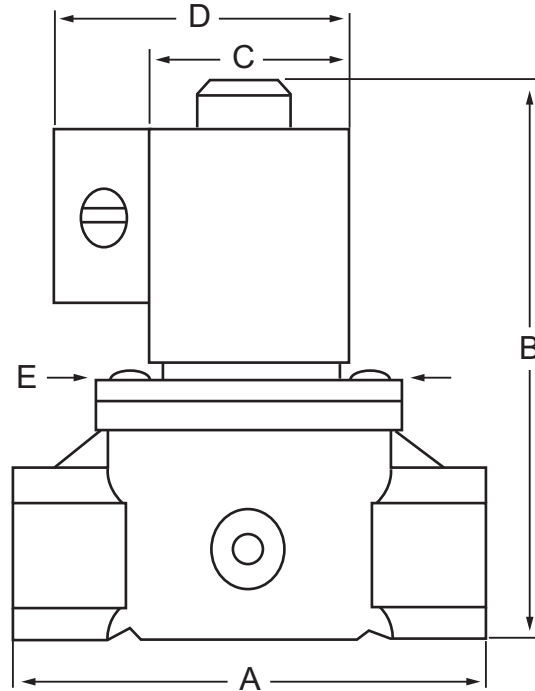

M28662

**Fig. 4. Dimensions (normally open).**

**Table 4. Normally Closed (See Fig. 3).**

Pipe size	A (inch)	B (inch)		C (inch)		D (inch)		E (inch) (both sides)	Weight (lbs)	
		2 psi	5 psi	2 psi	5 psi	2 psi	5 psi		2 psi	5 psi
3/8 in. NPT	2-7/8	4-7/16	4-7/16	2-3/16	2-3/16	3-3/4	3-3/4	2-3/16	2.5	2.2
1/2 in. NPT	2-7/8	4-7/16	4-7/16	2-3/16	2-3/16	3-3/4	3-3/4	2-3/16	2.5	2.2
3/4 in. NPT	3-7/16	5-1/4	5-13/16	2-3/16	2-1/2	3-3/4	4-1/16	2-3/4	4.0	4.4
1 in. NPT	3-15/16	5-1/4	6-5/16	2-3/16	2-1/2	3-3/4	4-1/16	3	4.5	4.4
1-1/4 in. NPT	5-15/16	8	8-9/16	2-1/2	3-5/16	4-1/16	4-15/16	4-3/8	12.8	10.6
1-1/2 in. NPT	5-15/16	8-3/8	8-9/16	3-3/8	3-5/16	4-15/16	4-15/16	4-3/8	12.8	10.6
2 in. NPT	6-11/16	8-3/8	9-3/16	3-3/8	3-3/4	4-15/16	5-5/16	5-3/8	14.0	13.4
2-1/2 in. NPT	9-1/2	12-3/4	—	4-9/16	—	6-1/8	—	7-7/8	28.5	—
3 in. NPT	9-1/2	12-3/4	—	4-9/16	—	6-1/8	—	7-7/8	31.0	—

**Table 5. Normally Open (See Fig. 4).**

Pipe size	A (inch)	B (inch)	C (inch)	D (inch)	E (inch) (both sides)	Weight (lbs)
3/4 in. NPT	3-7/16	5-1/2	2-3/16	3-3/4	2-3/4	4.0
1 in. NPT	3-15/16	5-1/2	2-3/16	3-3/4	3	4.5
1-1/4 in. NPT	5-15/16	8-3/4	2-1/2	4-1/16	4-3/8	12.8

## INSTALLATION

### When installing this product...

1. Read this instructions carefully. Failure to follow them could damage the product or cause a hazardous condition.
2. Check the rating given in the instructions and on the product to make sure the product is suitable for your application.
3. Installer must be a trained, experienced, flame safe-guard control technician.
4. After installation is complete, check out product operation as provided in these instructions.



### CAUTION

1. Turn off gas supply before starting installation.
2. Disconnect power supply before beginning installation to prevent electrical shock and equipment damage.
3. Do not remove seal over valve inlet or outlet until ready to connect piping.

### Prepare piping and install valve (Fig. 5)

1. Use new, properly reamed pipe which is free from chips.
2. Do not thread pipe too far.
3. Apply good quality pipe dope resistant to the action of LP gas, putting a moderate amount on the male threads only. If pipe dope lodges on the valve seat, it will prevent proper closure.
4. Install valve in a horizontal pipe line, (refer to Fig. 5 for mounting position) with the gas flow matching the direction indicated by the arrow on the casting.
5. Apply a parallel jaw wrench only to the wrench flats of the valve body, next to the pipe being inserted. A wrench applied to the valve body itself or to the end farthest from the pipe being inserted may distort the casting, resulting in malfunction on the gas valve.
6. The gas flow *must* be in the same direction as the arrow on the body of the valve.

## WARNING

If the flow is not in the same direction of arrow, valve may not shut off.

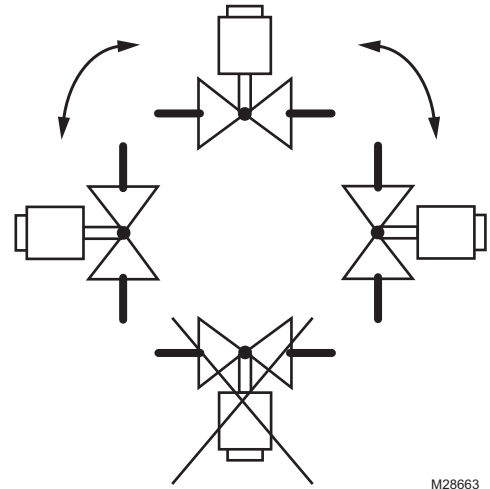

M28663

Fig. 5. Mounting position.

7. Make electrical connections as illustrated in the wiring diagrams; see Fig. 6.
8. Turn on main gas and with a soap solution, check valve installation for leaks.

## WIRING

1. Disconnect power supply **before** making wiring connections to prevent electrical shock and equipment damage.
2. Installation and wiring must be in conformance with National Electrical Code ANSI/NFPA 70, local codes and regulations.
3. For normal installations, use moisture-resistance No. 14 wire suitable for at least 167°F (75°C) if using a Flame Safeguard Primary Control, or 194°F (90°C) if using a Flame Safeguard Programming Control.
4. For high temperature installations, use moisture resistant No. 14 wire selected for a temperature rating above the maximum operating temperature.
5. Check the power supply circuit. The voltage and frequency must match those of the valve.
6. Refer to Fig. 6 for typical V4295A,S field wiring with RM7800 (typical) Primary Safety Control. Refer to Fig. 7 for typical V8295A,S field wiring with Primary Safety Control. Follow the burner manufacturer's wiring diagram, when provided. Refer to burner controller (primary safety control) wiring diagram for specific wiring terminal designations.
7. Make wiring connections at the electrical terminations provided in the wiring compartment of the valve.

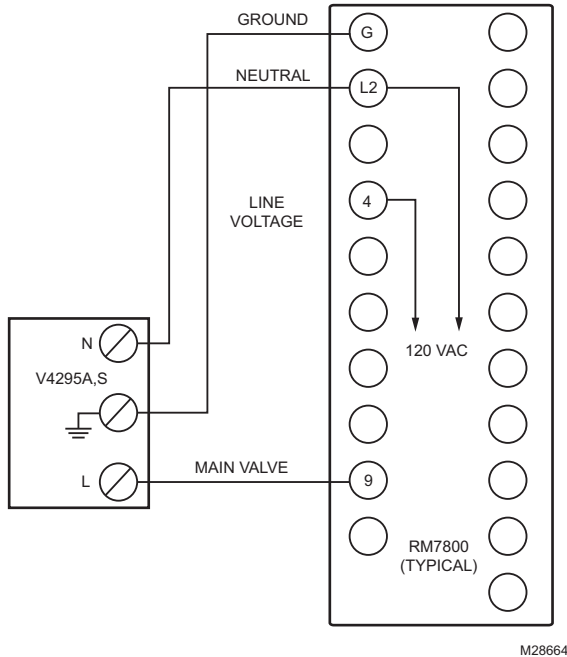

Fig. 6. Wiring, V4295A,S.

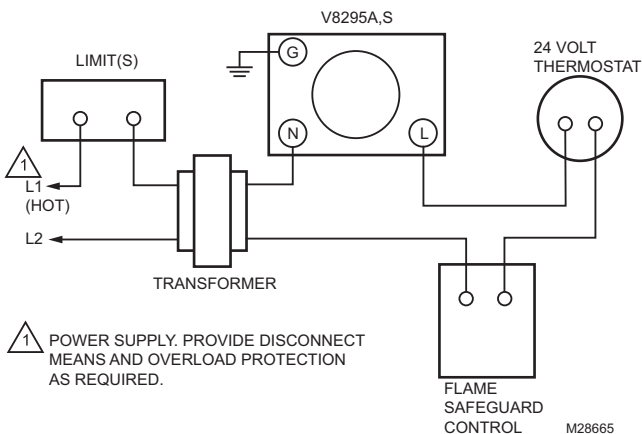

Fig. 7. Wiring, V8295A,S.

## OPERATION

The V4295A and V8295A Normally Closed series gas valves are Class B fail safe shut off valves. The valve is opened by energizing the direct ON/OFF operator. The direct ON/OFF operator consists of a coil and stop sleeve assembly. Inside the stop sleeve assembly is a plunger which is able to move up and down, thus opening or closing the valve. The plunger glides on two anti-friction bearings. A strainer, made of AISI 303 stainless steel, is incorporated into the valve.

## CHECKOUT AND TROUBLESHOOTING

### ⚠ WARNING

Do not allow fuel to accumulate in the combustion chamber. If fuel is allowed to enter the chamber for longer than a few seconds without igniting, an explosive mixture could result.

### ⚠ CAUTION

1. Do not put the system into service until you have satisfactorily completed all applicable tests described in the Checkout section of the instructions for the flame safeguard control and any other test required by the burner manufacturer.
2. Close *all* manual fuel shut off valves as soon as trouble occurs.

## CHECKOUT

1. Check the performance of the valve by measuring the pressures at the inlet and outlet pressure taps. The pressure reading at the outlet tap may be slightly higher than a downstream measurement due to dynamic gas flow effects. The measurement at the outlet tap is for reference only.
2. Shut off gas supply to valve and make sure valve is closed when setting up pressure measuring equipment.
3. Set thermostat or controller to energize the valve and check final outlet pressure.
4. Start the system and observe its operation through at least one complete cycle to ensure the valve functions as described in the section "Operation" on page 6.

## Valve Leak Test (Fig. 8)

This is a test for checking the closure tightness of the gas safety shutoff valve. It should be performed only by trained, experienced flame safeguard control technicians during the initial startup of the burner system or whenever the valve is replaced (see Service Information section). It is recommended that this test also be included in the scheduled inspection and maintenance procedures.

1. De-energize the control system to make sure no power goes to the valve (C, Fig. 8).
2. Close the upstream manual gas cock (A).
3. Make sure the manual test petcock (F) is closed in the leak test tap assembly (D).
4. Remove the leak test tap plug and connect the test apparatus to the leak test tap (D).
5. Close the downstream manual gas cock (E).
6. Open the upstream manual gas cock (A).
7. Run the V4/8295A Valve to is open position (through the safety system); then immediately de-energize the system to close the V4/8295A Valve.
8. Immerse a 1/4 in. (6 mm) tube vertically 1/2 in. (13 mm) into a jar of water.
9. Slowly open the manual test petcock (F).

10. When the rate of bubbles coming through the water stabilizes, count the number of bubbles appearing during a ten-second period. Each bubble appearing represents a flow rate of 0.001 cfh.

**IMPORTANT**

To meet U.S. requirements, make sure leakage does not exceed the rates in Table 6.

Table 6. Valve Allowable Leakage Rate.

V4295A/V8295A Pipe Size (in)	Medium	Allowable Leakage SCCH*	Maximum Number of Bubbles in 10 Seconds	Minimum Number of Seconds for 10 Bubbles
3/8 & 1/2	0.64 gas	294	7	13
	1.57 LP	188	4	20.4
3/4 & 1	0.64 gas	301	7	12.7
	1.57 LP	192	5	19.9
1-1/4 & 1-1/2	0.64 gas	532	13	7.2
	1.57 LP	341	8	11.2
2	0.64 gas	578	15	6.6
	1.57 LP	370	9	10.3
1-1/2	0.64 gas	752	19	5.1
	1.57 LP	481	12	8
3	0.64 gas	925	24	4.1
	1.57 LP	592	15	6.5

\* Based on air at standard conditions, test pressures provided by ANSI Z21.21, Section 2.42 and a maximum of 235 cc/h per inch of seal-off diameter (not pipe size).

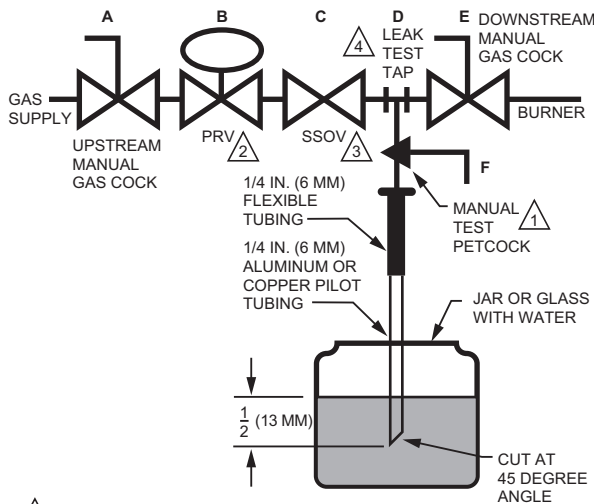

- 1 CAN ALSO BE A PERMANENT PETCOCK.
- 2 PRV = PRESSURE REGULATING VALVE.
- 3 SSOV = SAFETY SHUTOFF VALVE.
- 4 USE ONLY ONE OF THE DOWNSTREAM TAPS ON THE SSOV. M9547F

Fig. 8. Valve leak test.

NOTE: For international leak test requirements, contact the appropriate approval agency.

**After the Test**

1. Close the upstream manual gas cock (A).
2. Close the manual test petcock (F), remove the test apparatus, and close the leak test tap (D).
3. Make sure the downstream manual gas cock (E) is closed.
4. Open the upstream manual gas cock (A) and energize the V4/8295A Valve through the safety system.
5. Test with rich soap and water solution to make sure there is no leak at the leak test tap (D) or any pipe adapter/valve mating surfaces.
6. De-energize the V4/8295A Valve (C).
7. Open the downstream manual gas cock (E).
8. Restore the system to normal operation. If two safety shutoff valves are used, check each valve separately for closure tightness.

**TROUBLESHOOTING**

**CAUTION**

Use utmost care during troubleshooting. Line voltage is present at the actuator for V4295A,S and present in controller circuits. Low voltage (24 Vac) is present at the actuator for V8295A,S and present in controller circuits.

**IMPORTANT**

Do not assume that the valve must be replaced until all other sources of trouble have been eliminated.

1. **If the valve will not open when the thermostat or controller is calling for heat:**
  - a. Check that there is voltage at the valve actuator lead wires or terminal block.

## CAUTION

Line voltage (120 Vac) should be present when the primary safety control energizes the V4295A,S valve actuator. 24 Vac should be present when the primary safety control energizes the V8295A,S valve actuator.

- b. If there is no voltage at the actuator, first ensure line voltage power is connected to the master switch, the master switch is closed and overload protection (circuit breaker, fuse or similar device) has not opened the power line.
  - c. If there is still no voltage at the actuator, make sure all appropriate contacts in the thermostat (or controller), limit(s) and flame safeguard control are closed. If one or more are open, determine the cause(s) and correct condition(s) before proceeding.
  - d. If there is proper voltage at the actuator but the valve still does not open, first check that the gas pressure is normal.
  - e. If the valve still does not open, replace valve.
2. **If the valve will not close when one or more of the appropriate contacts in the thermostat (or controller), limit(s) or flame safeguard control is open:**

- a. Make sure that the gas flow is in the direction of the arrow on the valve body.
  - b. Make sure the valve actuator is wired in the correct circuit. Open the master switch to remove power from the actuator. If the valve closes now, the actuator may not be wired properly.
  - c. Look for a short in the electrical circuit.

## SERVICE INFORMATION

### CAUTION

1. **Only qualified service technicians should attempt to service or repair flame safeguard control and burner.**
2. **Line voltage is present in the electrical circuits to the valve. Open the master switch before replacing the valve.**

### CAUTION

1. **Label all wires prior to disconnection when servicing valves. Wiring errors can cause improper and dangerous operation.**
2. **Verify proper operation after servicing.**

## Scheduled inspection and maintenance

For periodic inspection and maintenance, set up a schedule and follow it. Include the burner, valves and all other burner controls. It is recommended that "Valve Leak Test (Fig. 8)" on page 6 be included in the schedule. Refer to the flame safeguard control instructions for more information.

### Automation and Control Solutions

Honeywell International Inc.  
1985 Douglas Drive North  
Golden Valley, MN 55422  
customer.honeywell.com

Honeywell Limited-Honeywell Limitée  
35 Dynamic Drive  
Toronto, Ontario M1V 4Z9

